



OFFICINA
PLUCE



perfection is achieved not
when there is nothing left to add,
but when there is nothing left
to take away.

– Antoine de Saint-Exupery, French aristocrat, writer and poet



INTRODUCTION

Welcome to Officina Luce, a luxurious brand at the height of decorative lighting perfection.

Born in the heart of Tuscany, as a business we collectively boast more than 30 years' experience producing the finest lighting designs in the world.

From exquisite chandeliers and floor lamps to opulent appliques and table lamps, our team of designers lead the industry with their stunning designs, expertly fusing contemporary chic with traditional elegance.

We hope you enjoy browsing through our latest lighting collection.



COMPANY BACKGROUND

Officina Luce creates unique decorative lighting fixtures that are admired across the globe and produces beautiful products capable of standing the test of time.

Our highly experienced team of designers dedicate themselves to making sure they meet your every need by producing truly bespoke products that are delivered to the highest standard and fulfil your exact requirements.



ETHOS

We pride ourselves on providing our clients with the very best in decorative lighting design. Each and every one of our products is created using the finest materials, utmost care and attention and highest level of traditional craftsmanship.

Attention to detail is paramount. From knowing where our materials are sourced and using skilled craftspeople, who have cultivated wood, metals and leather for generations, to effortlessly transforming visions into inspirational masterpieces, our expertise knows no bounds.

Our philosophy is simple; combining contemporary ideas with more established traditional methods and materials to create breath-taking designs that are based on logic and built to modern design standards.



ETEREA

Collection





ETEREA CHANDELIER

DIAM.90 X H.96 (CM) PLUS CHAIN

Structure in satin & polished nickel finish; gray leather upholsterings. Fumè crystal shades
Struttura in finitura nickel satinato e lucido; elementi in pelle grigia. Paralumi in cristallo fumè

3116-NN-FC



ETEREA CHANDELIER

DIAM.90 X H.96 (CM) PLUS CHAIN

Structure in satin & polished light gold finish; gray leather upholsterings. Transparent crystal shades
Struttura in finitura oro chiaro satinato e lucido; elementi in pelle grigia. Paralumi in cristallo trasparente

3116-GG-TC







ETEREA OVAL CHANDELIER

L.85 X D.60 X H.200 (CM)

Structure in satin & polished light gold finish; gray leather upholsterings. Transparent crystal shades
Struttura in finitura oro chiaro satinato e lucido; elementi in pelle grigia. Paralumi in cristallo trasparente

3112-GG-TC



ETEREA WALL LAMP

L.35 X D.20 X H.78 (CM)

Structure in satin & polished light gold finish. Transparent crystal shades
Struttura in finitura oro chiaro satinato e lucido. Paralumi in cristallo trasparente

3121-GG-TC



ETEREA WALL LAMP

L.35 X D.20 X H.78 (CM)

Structure in satin & polished nickel finish. Fumè crystal shades
Struttura in finitura nickel satinato e lucido. Paralumi in cristallo fumè

3121-NN-FC



ETEREA TABLE LAMP

DIAM.17 X H.70 (CM)

Structure in satin & polished light gold finish; metal base. Transparent crystal shades
Struttura in finitura oro chiaro satinato e lucido; base in metallo. Paralumi in cristallo trasparente



ETEREA TABLE LAMP

DIAM.17 X H.70 (CM)

Structure in satin & polished nickel finish; metal base. Blue crystal shades
Struttura in finitura nickel satinato e lucido; base in metallo. Paralumi in cristallo blu

3131-NN-BC





ETEREA FLOOR LAMP

DIAM.46 X H.190 (CM)

Structure in satin & polished nickel finish. Gray leather structure upholsterings; Bardiglio marble base. Fumè crystal shades
Struttura in finitura nickel satinato e lucido. Rivestimento struttura in pelle grigia; base in marmo Bardiglio. Paralumi in cristallo fumè

3141-NN-FC



ETEREA FLOOR-TO-CEILING FIXTURE

L.35 X D.16 X H.300 (CM)

Structure in polished gold finish. Gray leather extension; metal ceiling fixture and base. Transparent crystal shades
Struttura in finitura oro lucido; estensioni in pelle grigia; base ed attacco a soffitto in metallo. Paralumi in cristallo trasparente





SOAVE
Collection





SOAVE CHANDELIER

L.70 X D.48 X H.160 (CM) PLUS STEEL WIRE

Structure in satin copper finish; transparent and satin crystal shades
Struttura in finitura rame satinato; paralumi in cristallo trasparente e satinato

3211-RR-TC



SOAVE WALL LAMP

L.35 X D.20 X H.30 (CM)

Structure in satin copper finish; transparent and satin crystal shades
Struttura in finitura rame satinato; paralumi in cristallo trasparente e satinato

3221-RR-TC



SOAVE FLOOR LAMP

L.43 X D.27 X H.172 (CM)

Structure in satin & polished light gold finish; Bardiglio marble base. Transparent and satin crystal shades
Struttura in finitura oro chiaro satinato e lucido; base in marmo Bardiglio. Paralumi in cristallo trasparente e satinato

3241-GG-TC



ANIMA

Collection









ANIMA CHANDELIER

DIAM.39 X H.130 (CM) PLUS CHAIN

Structure in Walnut wood and satin & polished light gold finish; fumè crystal elements
Struttura in Noce e finitura oro chiaro satinato e lucido; elementi in cristallo fumè

3315-GG-FC



ANIMA WALL LAMP

L.16 X D.20 X H.154 (CM)

Structure in Walnut wood and satin & polished light gold finish; fumè crystal elements
Struttura in Noce e finitura oro chiaro satinato e lucido; elementi in cristallo fumè

3323-GG-FC



ANIMA WALL LAMP

L.36 X D.20 X H.84 (CM)

Structure in Walnut wood and satin & polished dark nickel finish; amber crystal elements
Struttura in Noce e finitura nickel nero satinato e lucido; elementi in cristallo ambra

3325-DN-AC





ANIMA FLOOR LAMP

L.25 X D.30 X H.184 (CM)

Structure in Walnut wood and satin & polished light gold finish; Travertino marble base. Fumè crystal elements
Struttura in Noce e finitura oro chiaro satinato e lucido; base in marmo Travertino. Elementi in cristallo fumè

3341-GG-FC



NEW FLOW

Collection





NEW FLOW CHANDELIER

DIAM.180 X H.195 (CM) PLUS CHAIN

Structure in satin gold finish; black leather inlays. Gold trevira wave shades
Struttura in finitura oro satinato; rivestimenti in pelle nera. Paralumi in rete trevira oro

2111-GK-24



NEW FLOW SPOT LIGHTS

DIAM.15 X H.40 (CM) EACH ITEM, PLUS WIRE

Structure in satin gold finish; black leather inlays
Struttura in finitura oro satinato; rivestimenti in pelle nera



NEW FLOW WALL LAMP

L.64 X D.38 X H.106 (CM)

Structure in satin gold finish; black leather inlays. Gold trevira wave shades
Struttura in finitura oro satinato; rivestimenti in pelle nera. Paralumi in rete trevira oro

2125-GK-24



FLOW

Collection





FLOW CHANDELIER

DIAM.145 X H.160 (CM) PLUS CHAIN

Structure in Ebony wood and satin gold finish; Gold trevira wave shades
Struttura in listelli di Ebano e finitura oro satinato; paralumi in rete trevira oro

1111-GW-24



FLOW CHANDELIER

DIAM.90 X H.105 (CM) PLUS CHAIN

Structure in Ebony wood and antiqued nickel finish; gold trevira wave shades
Struttura in listelli di Ebano e finitura nickel anticato; paralumi in rete trevira oro

1112-NW-24



FLOW CHANDELIER

DIAM.90 X H.105 (CM) PLUS CHAIN

Structure in Ebony wood and antiqued nickel finish; satin glass shades
Struttura in listelli di Ebano e finitura nickel anticato; paralumi in vetro satinato

1112-NW-S





FLOW WALL LAMP

L.56 X D.35 X H.92 (CM)

Structure in Ebony wood and antiqued nickel finish; gold trevira wave shades
Struttura in listelli di Ebano e finitura nickel anticato; paralumi in rete trevira oro

1125-NW-24



FLOW TABLE LAMP

DIAM.50 X H.91 (CM)

Structure in Ebony wood and antiqued nickel finish; metal base. Gold trevira wave shades
Struttura in listelli di Ebano e finitura nickel anticato; base in metallo. Paralumi in rete trevira oro



FLOW FLOOR LAMP

DIAM.66 X H.188 (CM)

Structure in Ebony wood and satin gold finish; metal base. Gold trevira wave shades
Struttura in listelli di Ebano e finitura oro satinato; base in metallo. Paralumi in rete trevira oro

1141-GW-24



NEW SHADE

Collection

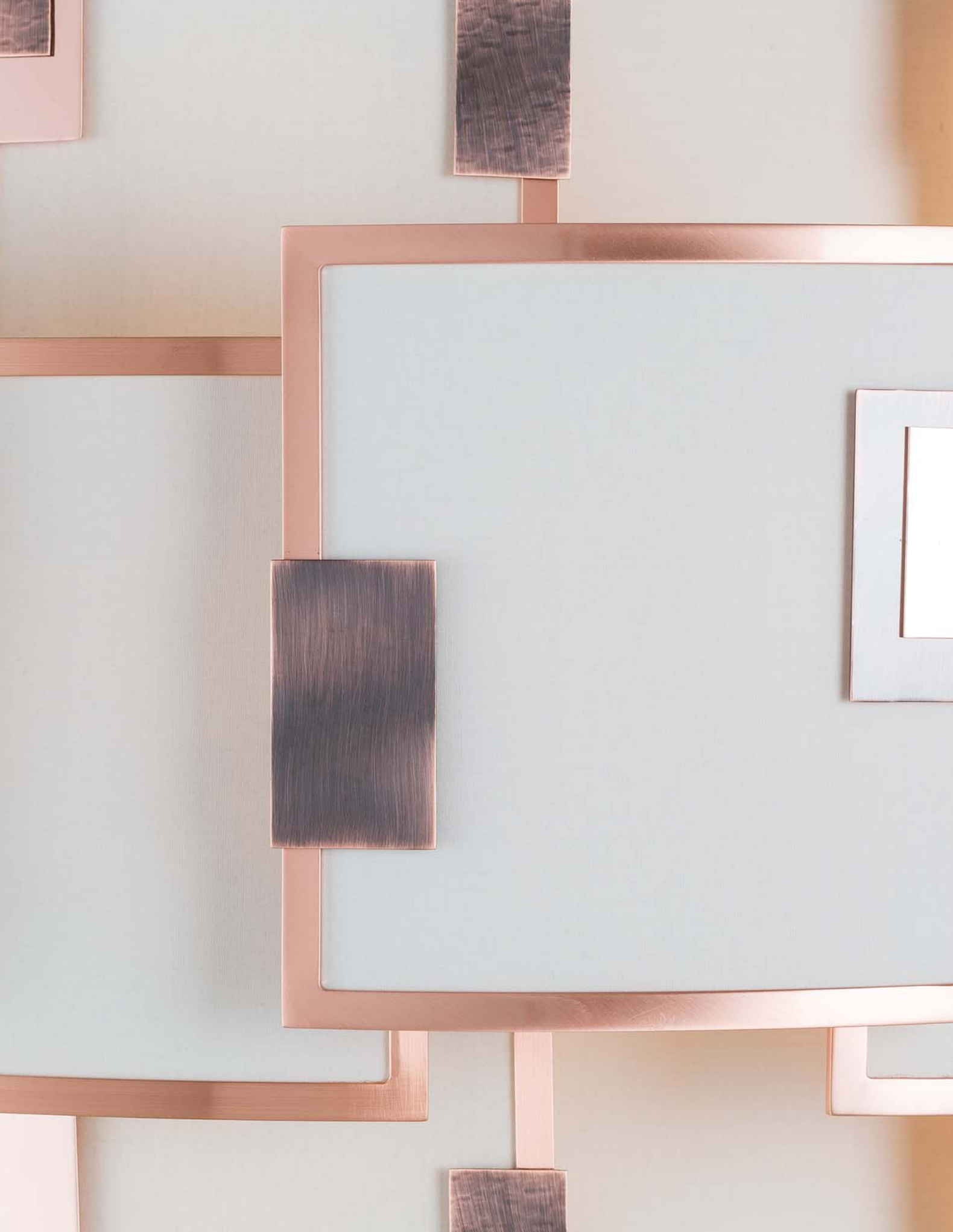



NEW SHADE CHANDELIER

DIAM.95 X H.139 (CM) PLUS CHAIN

Structure in polished copper finish; light gray linen shades
Struttura in rame lucido; paralumi in lino grigio chiaro

1311-RB-35



SHADE

Collection



SHADE MAXI WALL LAMP

L.52 X D.25 X H.65 (CM)

Structure in satin gold finish; light gray linen shades
Struttura in finitura oro satinato; paralumi in lino grigio chiaro

1421-GG-35



SHADE MAXI CHANDELIER

DIAM.140 X H.175 (CM) PLUS CHAIN

Structure in satin gold finish; white parchment shades
Struttura in finitura oro satinato; paralumi in pergamena bianca

1415-GG-08





SHADE MAXI CHANDELIER

DIAM.140 X H.175 (CM) PLUS CHAIN

Structure in polished nickel finish; ivory trevira wave shades
Struttura in finitura nickel lucido; paralumi in rete trevira avorio

1415-NN-22



SHADE CHANDELIER

DIAM.52 X H.85 (CM) PLUS CHAIN

Structure in polished nickel finish; light gray linen shades
Struttura in finitura nickel lucido; paralumi in lino grigio chiaro

1412-NN-35



SHADE CHANDELIER

DIAM.90 X H.121 (CM) PLUS CHAIN

Structure in satin gold finish; white parchment shades
Struttura in finitura oro satinato; paralumi in pergamena bianca

1411-GG-08



MARBLE FLAIRE

Collection



MARBLE FLAIRE FLOOR LAMP

DIAM.43 X H.185 (CM)

Structure in polished nickel finish and burnished brass; Carrara marble inlays and base. Light gray linen shade
Struttura in finitura nickel lucido ed ottone brunito; inserti e base in marmo di Carrara. Paralume in lino grigio chiaro



MARBLE FLAIRE CHANDELIER

DIAM.130 X H.100 (CM) PLUS CHAIN

Structure in polished nickel finish and burnished brass; Carrara marble inlays. Light gray linen shades
Struttura in finitura nickel lucido ed ottone brunito; inserti in marmo di Carrara. Paralumi in lino grigio chiaro

1613-BN-35



FLAIRE

Collection





FLAIRE OVAL DOUBLE LAYER CHANDELIER

L.145 X D.108 X H.133 (CM) PLUS CHAIN

Structure in burnished and natural brass; gold trevira wave shades
Struttura in ottone brunito e naturale; paralumi in rete trevira oro

414-BB-24



FLAIRE OVAL CHANDELIER

L.145 X D.108 X H.100 (CM) PLUS CHAIN

Structure in burnished and natural brass; ivory trevira wave shades
Struttura in ottone brunito e naturale; paralumi in rete trevira avorio



FLAIRE CHANDELIER

DIAM.85 X H.158 (CM) PLUS CHAIN

Structure in burnished and natural brass; ivory trevira wave shades
Struttura in ottone brunito e naturale; paralumi in rete trevira avorio

418-BB-22



FLAIRE CHANDELIER

DIAM.85 X H.78 (CM) PLUS CHAIN

Structure in burnished and natural brass; ivory trevira wave shades
Struttura in ottone brunito e naturale; paralumi in rete trevira avorio



FLAIRE WALL LAMP

L.18 X D.18 X H.72 (CM)

Structure in burnished and natural brass; ivory trevira wave shade
Struttura in ottone brunito e naturale; paralume in rete trevira avorio

421-BB-22



FLAIRE TABLE LAMP

DIAM.28 X H.71 (CM)

Structure in polished copper and black matte finish; metal base. Black trevira wave shade
Struttura in finitura rame lucido e nero opaco; base in metallo. Paralume in rete trevira nera

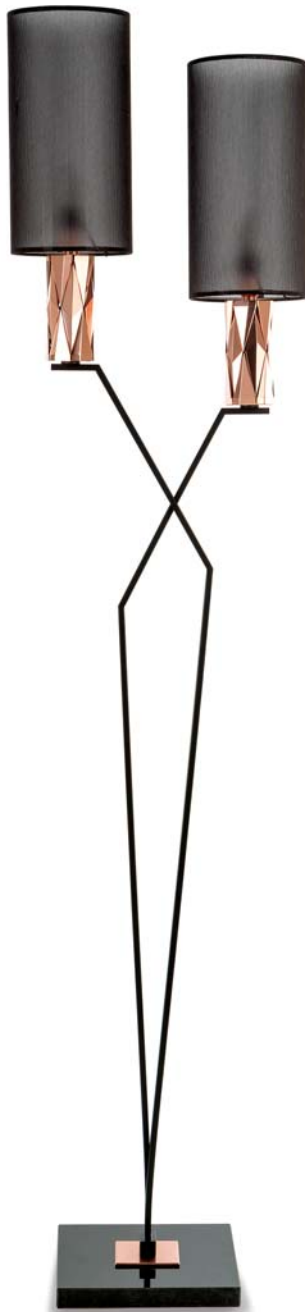

FLAIRE FLOOR LAMP

L.44 X D.28 X H.190 (CM)

Structure in polished copper and black matte finish; Marquinia marble base. Black trevira wave shades
Struttura in finitura rame lucido e nero opaco; base in marmo Marquinia. Paralumi in rete trevira nera

441-RK-25



FLAIRE TABLE LAMP

DIAM.51 X H.71 (CM)

Structure in burnished and natural brass; metal base. Ivory trevira wave shade
Struttura in ottone brunito e naturale; metal base. Paralume in rete trevira avorio



FLAIRE FLOOR LAMP

DIAM.43 X H.185 (CM)

Structure in burnished and natural brass; Portoro marble base. Ivory trevira wave shade
Struttura in ottone brunito e naturale; Portoro marble base. Paralume in rete trevira avorio

442-BB-22



GLAM
Collection



GLAM CHANDELIER

DIAM.110 X H.104 (CM) PLUS CHAIN

Structure in black nickel finish; details in polished and satin nickel finishes. Pink satin shades
Struttura in finitura nickel nero; dettagli in nickel lucido e satinato. Paralumi in raso rosa



GLAM SUSPENSION

DIAM.83 X H.104 (CM) PLUS CHAIN

Structure in black matte finish; details in black matte, polished and satin nickel finishes. Pink chinette shade
Struttura in finitura nero opaco; dettagli in finitura nero opaco, nickel lucido e satinato. Paralume in chinette rosa

756-NK-07





GLAM CHANDELIER

DIAM.110 X H.104 (CM) PLUS CHAIN

Structure in burnished brass; details in burnished&brushed and natural brass. Ivory shantung shades
Struttura in finitura ottone brunito; dettagli in ottone brunito&spazzolato e naturale. Paralumi in shantung avorio

711-BB-11



GLAM FLOOR LAMP

DIAM.50 X H.178 (CM)

Structure and details in burnished&brushed and natural brass; Portoro marble base. Ivory shantung shade
Struttura e dettagli in ottone brunito&spazzolato e naturale; base in marmo Portoro. Paralume in shantung avorio



GLAM SUSPENSION

DIAM.63 X H.30 (CM) PLUS STEEL WIRE

Structure in dark brown finish; details in burnished&brushed and natural brass. Polished white light diffuser disk
Struttura in finitura marrone scuro; dettagli in ottone brunito&spazzolato e naturale. Disco diffusore bianco lucido

750-BB



GLAM WALL LAMP

L.34 X D.20 X H.60 (CM)

Structure and details in burnished&brushed and natural brass. Ivory shantung shade
Struttura e dettagli in ottone brunito&spazzolato e naturale. Paralume in shantung avorio

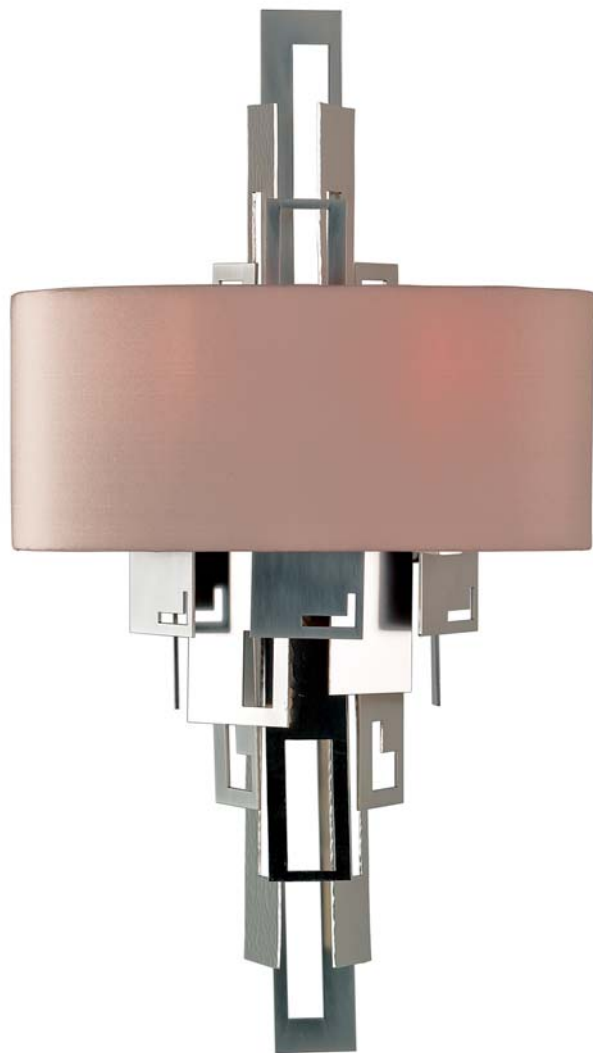

GLAM WALL LAMP

L.34 X D.20 X H.60 (CM)

Structure and details in polished and satin nickel finishes. Pink chinette shade
Struttura e dettagli in finitura nickel lucido e satinato. Paralume in chinette rosa

721-NN-07



GLAM TABLE LAMP

DIAM.28 X H.98 (CM)

Structure and details in polished and satin nickel finishes; Marquinia marble base. Pink chinette shade
Struttura e dettagli in finitura nickel lucido e satinato; base in marmo Marquinia. Paralume in chinette rosa



GLAM TABLE LAMP

DIAM.28 X H.98 (CM)

Structure and details in burnished&brushed and natural brass; Portoro marble base. Chestnut satin shade
Struttura e dettagli in ottone brunito&spazzolato e naturale; base in marmo Portoro. Paralume in raso castagna

731-BB-26



TOP
Collection



TOP WALL LAMP

L.18 X D.20 X H.40 (CM)

Structure in black matte finish; details in satin gold finish. Gold trevira wave shade
Struttura in finitura nero opaco; dettagli in finitura oro satinato. Paralume in rete trevira oro



TOP CHANDELIER

DIAM.94 X H.100 (CM) PLUS CHAIN

Structure in black matte finish; details in satin gold finish. Gold trevira wave shades
Struttura in finitura nero opaco; dettagli in finitura oro satinato. Paralumi in rete trevira oro

511-GK-24



TOP TABLE LAMP

DIAM.42 X H.72 (CM)

Structure in black matte finish; details in satin gold finish. Metal base. Gold trevira wave shade
Struttura in finitura nero opaco; dettagli in finitura oro satinato. Base in metallo. Paralume in rete trevira oro



TOP FLOOR LAMP

DIAM.50 X H.168 (CM)

Structure in black matte finish; details in satin gold finish. Metal base. Gold trevira wave shade
Struttura in finitura nero opaco; dettagli in finitura oro satinato. Base in metallo. Paralume in rete trevira oro

541-GK-24

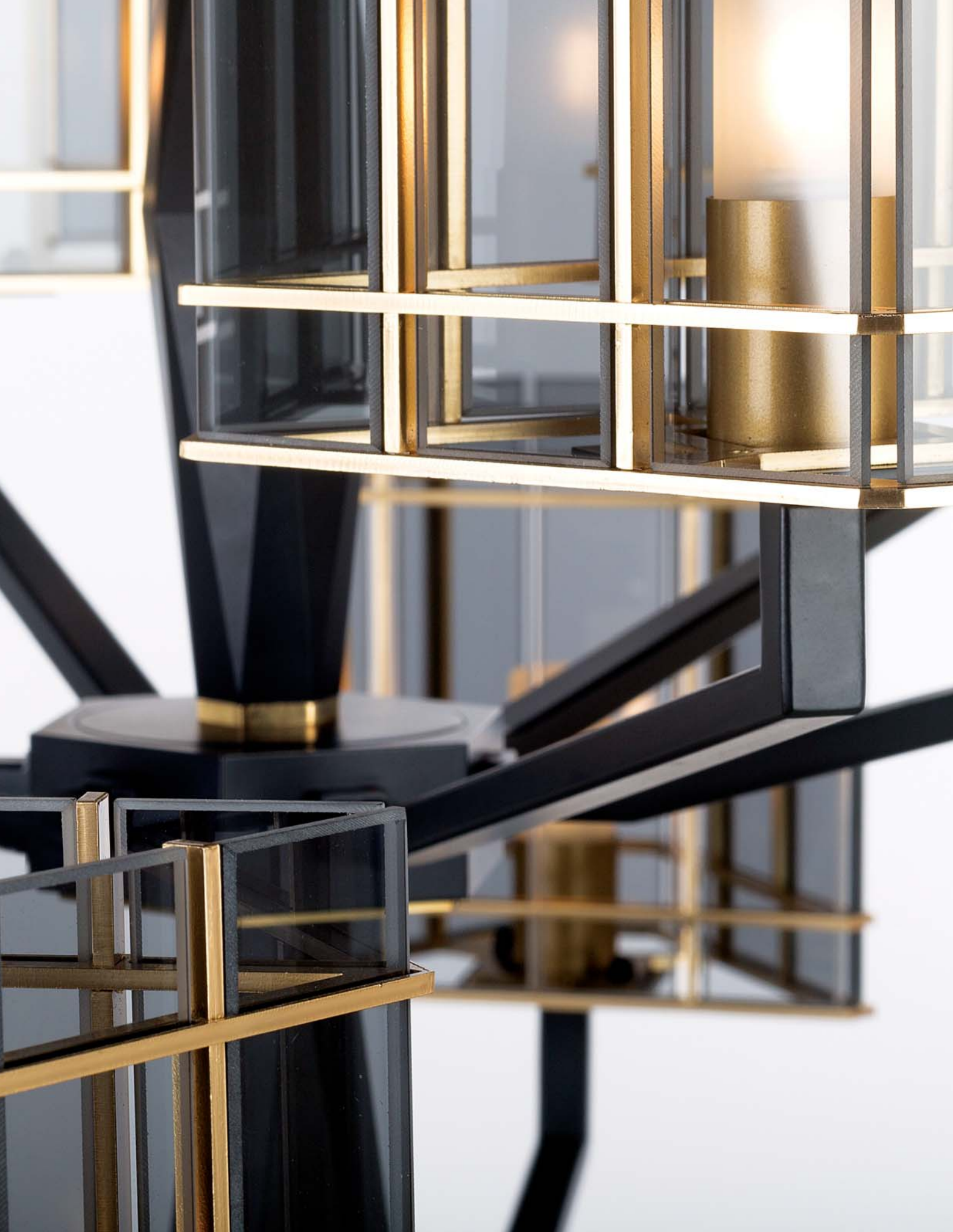

TOP GLASS

Collection



TOP GLASS CHANDELIER

DIAM.98 X H.100 (CM) PLUS CHAIN

Structure in black matte finish; details in satin gold finish. Transparent fumè glass shades
Struttura in finitura nero opaco; dettagli in finitura oro satinato. Paralumi in vetro fumè trasparente



TOP GLASS CHANDELIER

DIAM.98 X H.96 (CM) PLUS CHAIN

Structure in black matte finish; details in satin gold finish. Transparent fumè glass shades
Struttura in finitura nero opaco; dettagli in finitura oro satinato. Paralumi in vetro fumè trasparente

613-GK-X



TOP GLASS WALL LAMP

L.19 X D.16 X H.30 (CM)

Structure in black matte finish; details in satin gold finish. Transparent fumè glass shade
Struttura in finitura nero opaco; dettagli in finitura oro satinato. Paralume in vetro fumè trasparente

621-GK-X



TOP GLASS WALL LAMP

L.23 X D.19 X H.48 (CM)

Structure in black matte finish; details in satin gold finish. Transparent fumè glass shade
Struttura in finitura nero opaco; dettagli in finitura oro satinato. Paralume in vetro fumè trasparente

623-GK-X



TOP GLASS TABLE LAMP

L.32 X D.24 X H.53 (CM)

Structure in black matte finish; details in satin gold finish. Metal base. Transparent fumè glass shade
Struttura in finitura nero opaco; dettagli in finitura oro satinato. Base in metallo. Paralume in vetro fumè trasparente



TOP GLASS FLOOR LAMP

L.49 X D.32 X H.160 (CM)

Structure in black matte finish; details in satin gold finish. Metal base. Transparent fumè glass shade
Struttura in finitura nero opaco; dettagli in finitura oro satinato. Base in metallo. Paralume in vetro fumè trasparente

641-GK-X



TOP GLASS TABLE LAMP

L.23 X D.24 X H.46 (CM)

Structure in black matte finish; details in satin gold finish. Metal base. Transparent fumè glass shade
Struttura in finitura nero opaco; dettagli in finitura oro satinato. Base in metallo. Paralume in vetro fumè trasparente



TOP GLASS FLOOR LAMP

L.23 X D.28 X H.140 (CM)

Structure in black matte finish; details in satin gold finish. Metal base. Transparent fumè glass shade
Struttura in finitura nero opaco; dettagli in finitura oro satinato. Base in metallo. Paralume in vetro fumè trasparente

642-GK-X



SABA
Collection





SABA CEILING LAMP

DIAM.60 X H.111 (CM)

Structure and details in brushed&burnished and natural brass. Ivory crepon plissé shades; white cotton light diffuser disks
Struttura e dettagli in ottone brunito&spazzolato e naturale. Paralumi in crepon avorio plissettato; dischi diffusori in cotone bianco

1011-BB-01





SABA WALL LAMP

L. 19 X D.20 X H.43 (CM)

Structure in natural and burnished brass. Ivory trevira wave shade
Struttura in ottone naturale e brunito. Paralume in rete trevira avorio

1021-BB-22



SABA FLOOR LAMP

DIAM.60 X H.183 (CM)

Structure in natural brass; base in brushed&burnished brass. Metal base. Ivory crepon plissé shade
Struttura in ottone naturale; base in ottone brunito&spazzolato. Base in metallo. Paralume in crepon avorio plissettato



SABA TABLE LAMP

DIAM.50 X H.88 (CM)

Structure in natural brass; base in brushed&burnished brass. Metal base. Ivory crepon plissé shade
Struttura in ottone naturale; base in ottone brunito&spazzolato. Base in metallo. Paralume in crepon avorio plissettato

1031-BB-01



SABA TABLE LAMP

L.32 X D.32 X H.73 (CM)

Structure and base in polished and satin nickel finishes; metal base. Ivory trevira wave shade
Struttura e base in finiture nickel satinato e lucido; base in metallo. Paralume in rete trevira avorio



SABA FLOOR LAMP

DIAM.60 X H.183 (CM)

Structure and base in polished dark and satin nickel finishes; metal base. Gold trevira wave shade; black leather details
Struttura e base in finiture nickel satinato e nero lucido; base in metallo. Paralume in rete trevira oro; bordi in pelle nera

1041-NN-24



BLOOM

Collection

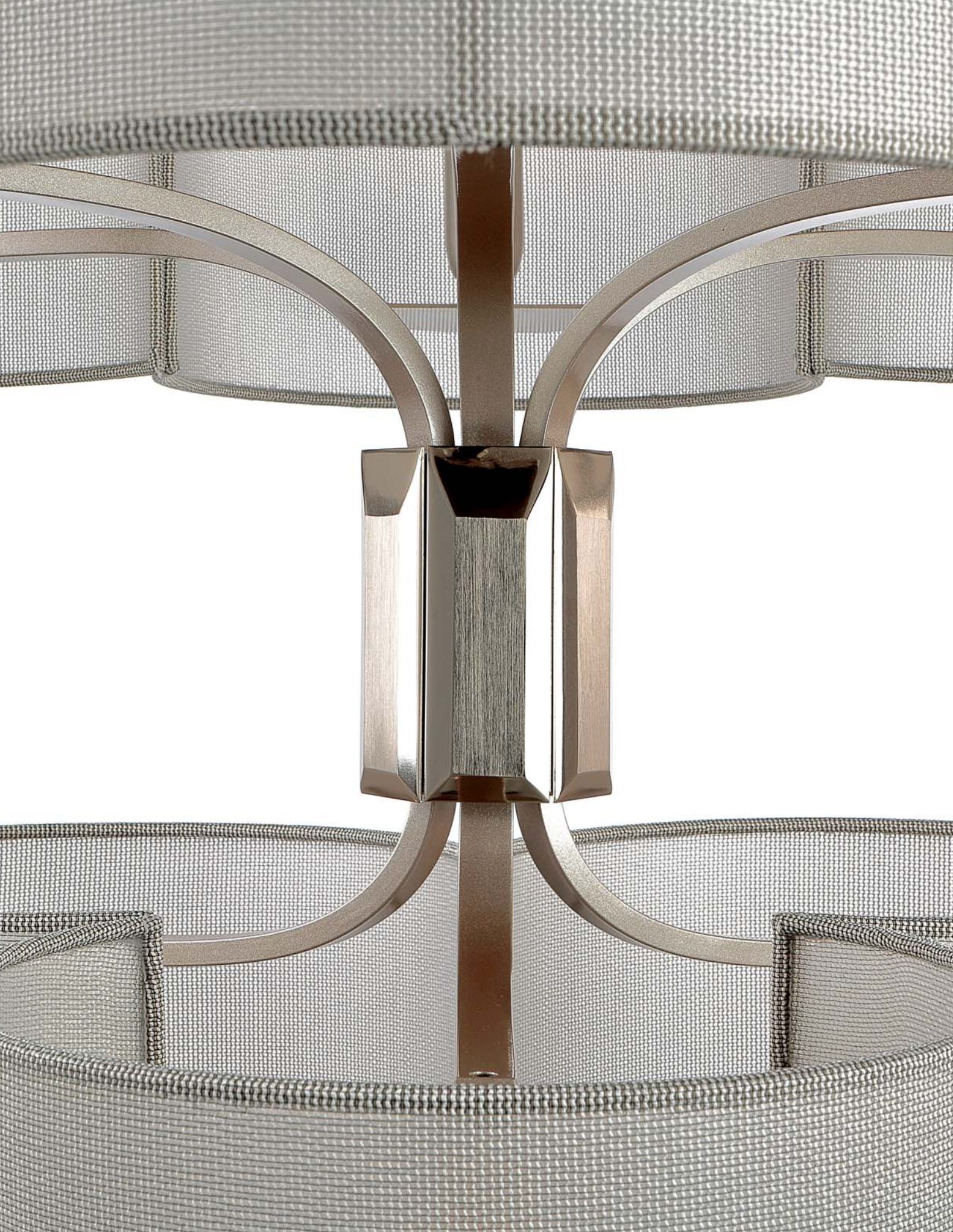



BLOOM DOUBLE CHANDELIER

DIAM.76 X H.130 (CM) PLUS CHAIN

Structure in beige finish and details in polished and satin nickel finishes. Silver trevira wave shades
Struttura in finitura beige e e dettagli in finitura nickel lucido e satinato. Paralumi in rete trevira argento

311-NJ-23



BLOOM CHANDELIER

DIAM.76 X H.92 (CM) PLUS CHAIN

Structure in black matte finish and details in polished and satin gold finishes. Beige satin shades
Struttura in finitura nero matte e dettagli in finitura oro lucido e satinato. Paralumi in raso beige





BLOOM WALL LAMP

L.42 X D.23 X H.70 (CM)

Structure in black matte finish and details in polished and satin gold finishes. Beige satin shades
Struttura in finitura nero matte e dettagli in finitura oro lucido e satinato. Paralumi in raso beige



BLOOM WALL LAMP

L.42 X D.23 X H.70 (CM)

Structure in beige finish and details in polished and satin nickel finishes. Silver trevira wave shades
Struttura in finitura beige e e dettagli in finitura nickel lucido e satinato. Paralumi in rete trevira argento

321-NJ-23



BLOOM TABLE LAMP

D.52 X H.78 (CM)

Structure in beige finish and details in polished and satin nickel finishes; metal base. Silver trevira wave shades; white cotton light diffuser disk
Struttura in finitura beige e e dettagli in finitura nickel lucido e satinato; base in metallo. Paralumi in rete trevira argento; dischi diffusori in cotone bianco



BLOOM FLOOR LAMP

D.64 X H.180 (CM)

Structure in black matte finish and details in polished and satin gold finishes; metal base. Beige satin shades
Struttura in finitura nero matte e dettagli in finitura oro lucido e satinato; base in metallo. Paralumi in raso beige

341-GK-30

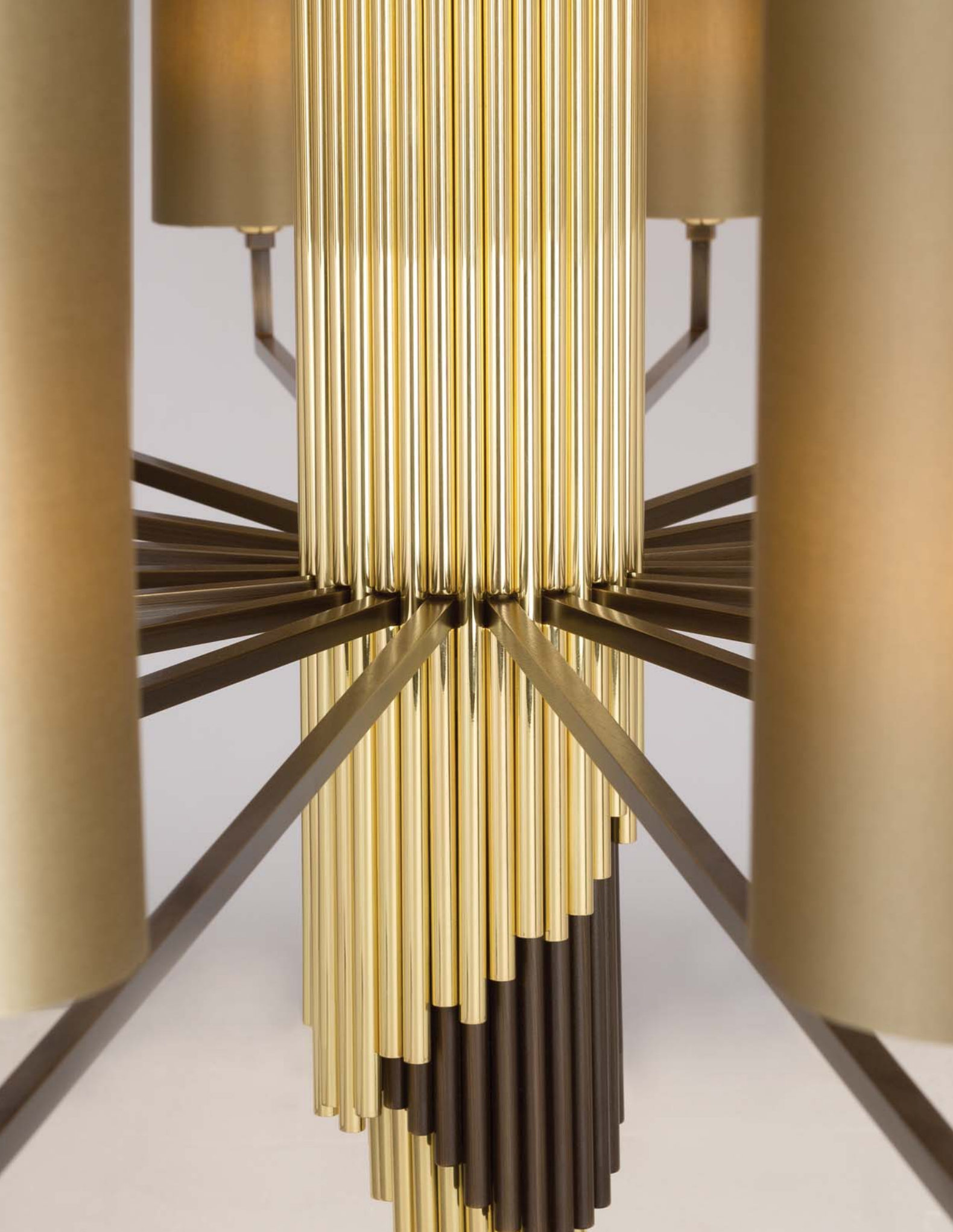

SHINE

Collection





SHINE CHANDELIER

DIAM.154 X H.170 (CM) PLUS CHAIN

Structure and details in burnished and natural brass. Sage green satin shades
Struttura e dettagli in ottone brunito e naturale. Paralumi in raso verde salvia

2811-BB-41



SHINE WALL LAMP

L.35 X D.19 X H.70 (CM)

Structure and details in burnished and natural brass. Sage green satin shade
Struttura e dettagli in ottone brunito e naturale. Paralume in raso verde salvia

2822-BB-41



SHINE TABLE LAMP

DIAM.43 X H.65 (CM)

Structure and details in burnished and natural brass; metal base. Sage green satin shade
Struttura e dettagli in ottone brunito e naturale; base in metallo. Paralume in raso verde salvia

2833-BB-41



SHINE TABLE LAMP

DIAM.43 X H.65 (CM)

Structure and details in polished and satin nickel finish; metal base. Sage green satin shade
Struttura e dettagli in finitura nickel lucido e satinato; base in metallo. Paralume in raso verde salvia



SHINE CHANDELIER

DIAM.95 X H.110 (CM) PLUS CHAIN

Structure and details in polished and satin nickel finish. Sage green satin shades
Struttura e dettagli in finitura nickel lucido e satinato. Paralumi in raso verde salvia

2817-NN-41



CREA
Collection





CREA CHANDELIER

DIAM.75 X H.165 (CM) PLUS CHAIN

Structure in burnished brass; details in brushed&burnished and natural brass. Gold trevira wave shades
Struttura in ottone brunito; dettagli in ottone brunito&spazzolato e naturale. Paralumi in rete trevira oro

211-BB-24





CREA WALL LAMP

L.33 X D.33 X H.150 (CM)

Structure in burnished brass; details in brushed&burnished and natural brass. Pink satin shade
Struttura in ottone brunito; dettagli in ottone brunito&spazzolato e naturale. Paralume in raso rosa

221-BB-33



CREA WALL LAMP

L.33 X D.33 X H.150 (CM)

Structure in black matte finish; details in polished and satin nickel finishes. White pongè shade
Struttura in finitura nero matte; dettagli in nickel lucido e satinato. Paralume in pongè bianco

221-NK-04



CREA WALL LAMP

L.49 X D.23 X H.40 (CM)

Structure in white finish; details in polished and satin nickel finishes. Ivory trevira wave shades
Struttura in finitura bianca; dettagli in nickel lucido e satinato. Paralumi in rete trevira avorio

222-NC-22



CREA WALL LAMP

L.49 X D.23 X H.40 (CM)

Structure in burnished brass; details in brushed&burnished and natural brass. Pink satin shades
Struttura in ottone brunito; dettagli in ottone brunito&spazzolato e naturale. Paralumi in raso rosa



CREA FLOOR LAMP

DIAM.65 X H.194 (CM)

Structure in black matte finish; details in polished and satin gold finishes. Metal base. Ivory shantung shades
Struttura in finitura nera matte; dettagli in finitura oro lucido e satinato. Base in metallo. Paralumi in shantung avorio

241-GK-11



NEST

Collection





NEST CHANDELIER

DIAM.90 X H.110 (CM)

Structure in polished light gold finish. Shades in copper finish metal mesh and cream satin; white cotton light diffuser disk
Struttura in finitura oro lucido chiaro. Paralumi in rete metallica in finitura rame e raso crema; disco diffusore in cotone bianco

4111-GG-MR



NEST FLOOR LAMP

DIAM.52 X H.195 (CM)

Structure in polished light gold finish. Shades in copper finish metal mesh and cream satin; white cotton light diffuser disk
Struttura in finitura oro lucido chiaro. Paralumi in rete metallica in finitura rame e raso crema; disco diffusore in cotone bianco



NEST TABLE LAMP

DIAM.42 X H.68 (CM)

Structure in polished light gold finish. Shades in copper finish metal mesh and cream satin; white cotton light diffuser disk
Struttura in finitura oro lucido chiaro. Paralumi in rete metallica in finitura rame e raso crema; disco diffusore in cotone bianco

4131-GG-MR



TRAPEZE

Collection





TRAPEZE CHANDELIER

L.156 X D.60 X H.95 (CM)

Structure and details in burnished and natural brass. Gold trevira wave shades
Struttura e dettagli in ottone brunito e naturale. Paralumi in rete trevira oro

812-BB-24



TRAPEZE WALL LAMP

L.61 X D.30 X H.46 (CM)

Structure and details in burnished and natural brass. Gold trevira wave shades
Struttura e dettagli in ottone brunito e naturale. Paralumi in rete trevira oro

823-BB-24



TRAPEZE FLOOR LAMP

L.48 X D.32 X H.180 (CM)

Structure and details in burnished and natural brass. Metal base. Beige linen shade
Struttura e dettagli in ottone brunito e naturale. Base in metallo. Paralume in lino beige

841-BB-27



GRACE
Collection



GRACE TABLE LAMP

L.48 X D.31 X H.110 (CM)

Structure and details in black matte and satin gold finishes. Metal base. Ivory satin shade
Struttura e dettagli in finitura nero matte ed oro satinato. Base in metallo. Paralume in raso avorio



GRACE SUSPENSION

DIAM.52 X H.125 (CM) PLUS CHAIN

Structure and details in satin gold and black matte finishes. Ivory satin shades
Struttura e dettagli in finitura oro satinato e nero matte. Paralumi in raso avorio

1212-GK-28



FLUTE

Collection



FLUTE TABLE LAMP

DIAM.33 X H.65 (CM)

Structure in natural brass; ochre galuchat upholstered panels. Calacatta marble base. Ivory satin shade
Struttura in ottone naturale; pannelli rivestiti in galuchat ocra. Base in marmo Calacatta. Paralume in raso avorio



FLUTE TABLE LAMP

DIAM.33 X H.65 (CM)

Structure in natural brass; dark gray galuchat upholstered panels. Portoro marble base. Beige satin shade
Struttura in ottone naturale; pannelli rivestiti in galuchat antracite. Base in marmo Portoro. Paralume in raso beige

131-BB-30



FLUTE TABLE LAMP

DIAM.33 X H.65 (CM)

Structure in dark nickel finish; dark gray galuchat upholstered panels. Marquinia marble base. Gray satin shade
Struttura in finitura nickel nero; pannelli rivestiti in galuchat antracite. Base in marmo Marquinia. Paralume in raso grigio



FLUTE TABLE LAMP

DIAM.33 X H.65 (CM)

Structure in polished nickel finish; light green galuchat upholstered panels. Carrara marble base. Sage green satin shade
Struttura in finitura nickel lucido; pannelli rivestiti in galuchat verde pastello. Base in marmo Carrara. Paralume in raso verde salvia

131-NN-41



CERAMICS

Collection



CERAMICS TABLE LAMP

DIAM.50 X H.90 (CM)

Ceramic structure in ocean blue finish and details in natural brass. Light gray shantung shade
Base ceramica in finitura blu oceano e dettagli in ottone naturale. Paralume in shantung grigio chiaro



CERAMICS TABLE LAMP

DIAM.50 X H.90 (CM)

Ceramic structure in antiqued ivory finish and details in natural brass. Gold trevira wave shade
Base ceramica in finitura avorio invecchiato e dettagli in ottone naturale. Paralume in rete trevira oro

1531-GI-24



TECHNICAL SHEETS

FLUTE

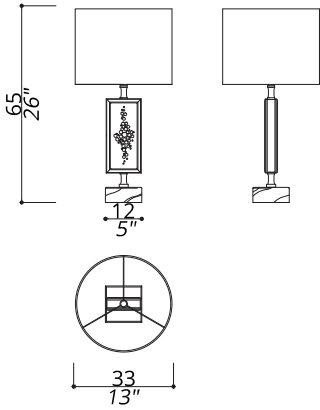

131-BB-30	TABLE LAMP	TWO-SIDED FRAME IN GALUCHAT UPHOLSTERY. STRUCTURE IN F_10 (NATURAL BRASS); DARK GRAY GALUCHAT. PORTORO MARBLE BASE.	1 LIGHT TYPE E27
131-BB-28	TABLE LAMP	STRUCTURE IN F_10 (NATURAL BRASS); LIGHT BROWN GALUCHAT. CALACATTA GOLD MARBLE BASE.	1 LIGHT TYPE E27
131-NN-41	TABLE LAMP	STRUCTURE IN F_31 (POLISHED NICKEL FINISH); LIGHT GREEN GALUCHAT. CARRARA MARBLE BASE.	1 LIGHT TYPE E27
131-DN-29	TABLE LAMP	STRUCTURE IN F_41 (POLISHED BLACK NICKEL FINISH); DARK GRAY GALUCHAT. MARQUINIA MARBLE BASE.	1 LIGHT TYPE E27

CREA

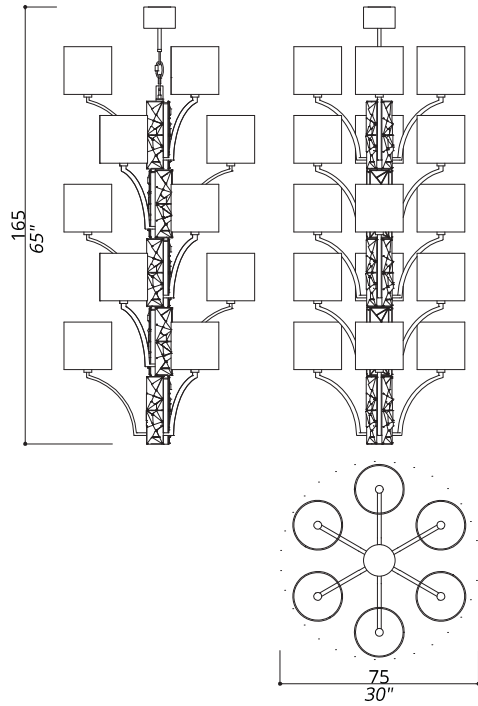

211-BB-24	MODULAR CHANDELIER	FIVE MODULAR FIXTURES COMPOSITION. CENTRAL STRUCTURE OF 3D DESIGNED PANELS IN SOLID BRASS. 50 CM OF CHAIN INCLUDED. STRUCTURE IN F_13 (BURNISHED BRASS FINISH); TILES IN F_12 (BRUSHED & BURNISHED BRASS); CONNECTION BOX AND DETAILS IN F_10 (NATURAL BRASS).	15 LIGHTS TYPE E14
------------------	--------------------	--	-----------------------

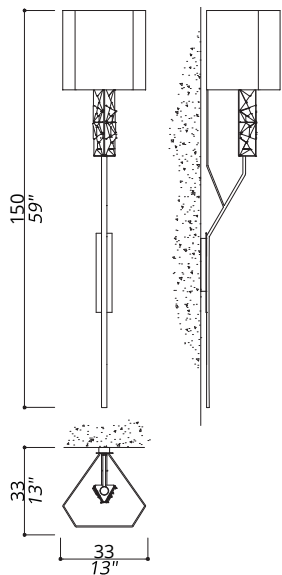

221-NK-04	WALL LAMP	CENTRAL STRUCTURE OF 3D DESIGNED PANELS IN SOLID BRASS. STRUCTURE IN L_56 (BLACK MATTE FINISH); TILES IN F_33 (SATIN NICKEL FINISH); DETAILS AND CONNECTION BOX IN F_31 (POLISHED NICKEL FINISH).	1 LIGHT TYPE E27
221-BB-33	WALL LAMP	STRUCTURE IN F_13 (BURNISHED BRASS FINISH); TILES IN F_12 (BRUSHED & BURNISHED BRASS); CONNECTION BOX AND DETAILS IN F_10 (NATURAL BRASS).	1 LIGHT TYPE E27

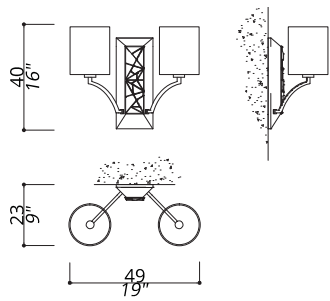

222-NC-23

WALL LAMP

ONE MODULE COMPOSITION. CENTRAL STRUCTURE OF 3D DESIGNED PANELS IN SOLID BRASS.
STRUCTURE IN L_57; TILES IN F_33; DETAILS AND CONNECTION BOX IN F_31.

2 LIGHTS
TYPE E14

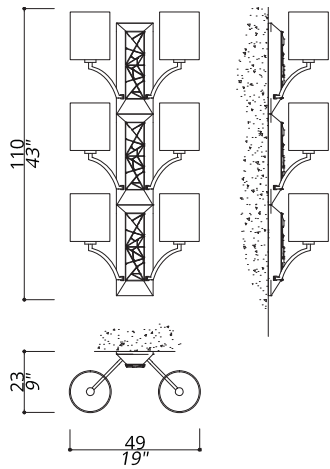

223-GJ-33

WALL LAMP

THREE MODULES COMPOSITION. CENTRAL STRUCTURE OF 3D DESIGNED PANELS IN SOLID BRASS.

STRUCTURE IN L_55 (BEIGE FINISH); TILES IN F_15 (SATIN GOLD FINISH); DETAILS AND CONNECTION BOX IN F_14 (POLISHED GOLD FINISH).

6 LIGHTS
TYPE E14

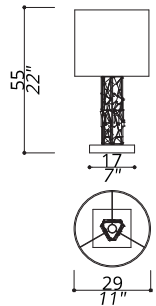

231-BB-28

TABLE LAMP

CENTRAL STRUCTURE OF 3D DESIGNED PANELS IN SOLID BRASS.
STRUCTURE AND CONNECTION BOX IN F_13 (BURNISHED BRASS FINISH); TILES IN F_12 (BRUSHED & BURNISHED BRASS); DETAILS IN F_10 (NATURAL BRASS).
METAL BASE.

1 LIGHT
TYPE E27

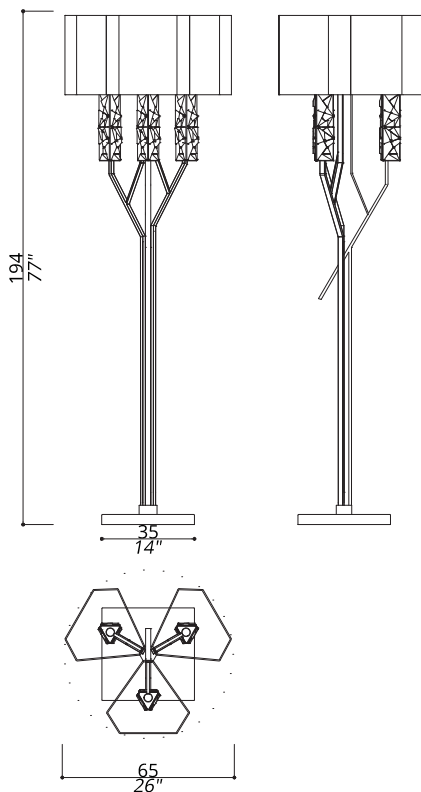

241-GK-11

FLOOR LAMP

CENTRAL STRUCTURES OF 3D DESIGNED PANELS IN SOLID BRASS.

STRUCTURE IN L_56 (BLACK MATTE FINISH); TILES IN F_15 (SATIN GOLD FINISH); DETAILS IN F_14 (POLISHED GOLD FINISH).
METAL BASE.

3 LIGHTS
TYPE E27

BLOOM

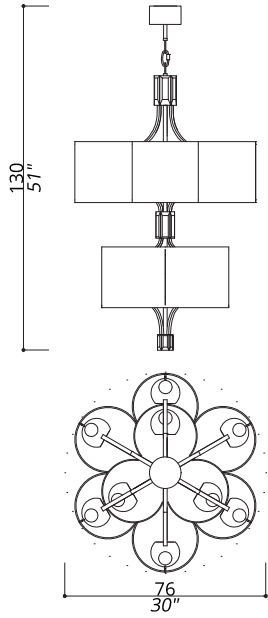

311-NJ-23

MODULAR
CHANDELIER

TWO LAYER COMPOSITION OF SIX PLUS THREE PETAL-SHAPED SHADES. 50 CM OF CHAIN INCLUDED.

STRUCTURE IN L_55 (BEIGE FINISH); CONNECTION BOX AND DETAILS IN F_31 (POLISHED NICKEL FINISH) AND F_33 (SATIN NICKEL FINISH).

9 LIGHTS
TYPE E14

311-GK-30

MODULAR
CHANDELIER

STRUCTURE IN L_56 (BLACK MATTE FINISH); CONNECTION BOX AND DETAILS IN F_14 (POLISHED GOLD FINISH) AND F_15 (SATIN GOLD FINISH).

9 LIGHTS
TYPE E14

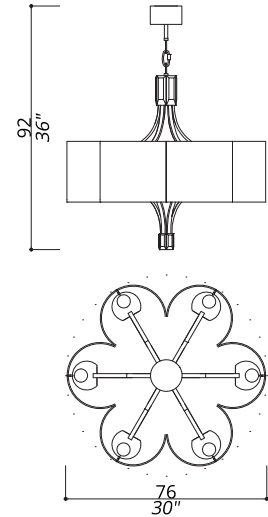

312-NJ-23

CHANDELIER

ONE LAYER COMPOSITION OF SIX PETAL-SHAPED SHADES. 50 CM OF CHAIN INCLUDED.

STRUCTURE IN L_55 (BEIGE FINISH); CONNECTION BOX AND DETAILS IN F_31 (POLISHED NICKEL FINISH) AND F_33 (SATIN NICKEL FINISH).

6 LIGHTS
TYPE E14

312-GK-30

CHANDELIER

STRUCTURE IN L_56 (BLACK MATTE FINISH); CONNECTION BOX AND DETAILS IN F_14 (POLISHED GOLD FINISH) AND F_15 (SATIN GOLD FINISH).

6 LIGHTS
TYPE E14

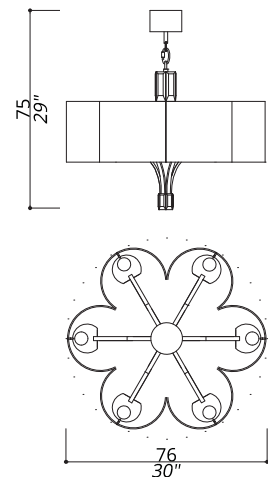

313-NJ-23

CHANDELIER

ONE LAYER COMPOSITION OF SIX PETAL-SHAPED SHADES. 50 CM OF CHAIN INCLUDED.

STRUCTURE IN L_55 (BEIGE FINISH); CONNECTION BOX AND DETAILS IN F_31 (POLISHED NICKEL FINISH) AND F_33 (SATIN NICKEL FINISH).

6 LIGHTS
TYPE E14

313-GK-30

CHANDELIER

STRUCTURE IN L_56 (BLACK MATTE FINISH); CONNECTION BOX AND DETAILS IN F_14 (POLISHED GOLD FINISH) AND F_15 (SATIN GOLD FINISH).

6 LIGHTS
TYPE E14

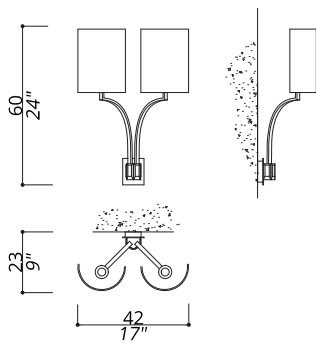

321-NJ-23 WALL LAMP STRUCTURE IN L_55 (BEIGE FINISH); CONNECTION BOX AND DETAILS IN F_31 (POLISHED NICKEL FINISH) AND F_33 (SATIN NICKEL FINISH). 2 LIGHTS TYPE E14

321-GK-30 WALL LAMP STRUCTURE IN L_56 (BLACK MATTE FINISH); CONNECTION BOX AND DETAILS IN F_14 (POLISHED GOLD FINISH) AND F_15 (SATIN GOLD FINISH). 2 LIGHTS TYPE E14

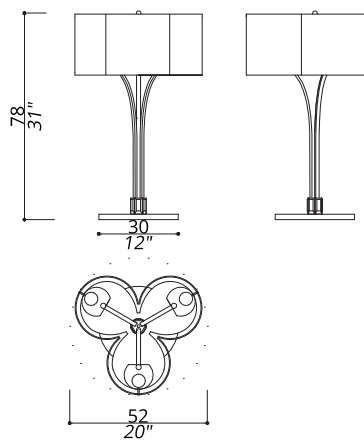

331-NJ-23 TABLE LAMP THREE PETAL-SHAPED SHADES COMPOSITION. STRUCTURE AND BASE IN L_55 (BEIGE FINISH); DETAILS IN F_31 (POLISHED NICKEL FINISH) AND F_33 (SATIN NICKEL FINISH). METAL BASE. 3 LIGHTS TYPE E14

331-GK-30 TABLE LAMP STRUCTURE AND BASE IN L_56 (BLACK MATTE FINISH); DETAILS IN F_14 (POLISHED GOLD FINISH) AND F_15 (SATIN GOLD FINISH). METAL BASE. 3 LIGHTS TYPE E14

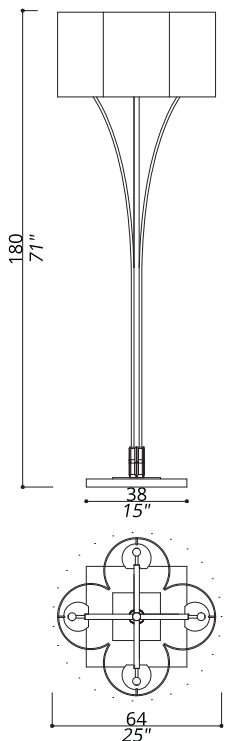

341-NJ-23 FLOOR LAMP FOUR PETAL-SHAPED SHADES COMPOSITION. STRUCTURE AND BASE IN L_55 (BEIGE FINISH); DETAILS IN F_31 (POLISHED NICKEL FINISH) AND F_33 (SATIN NICKEL FINISH). METAL BASE. 4 LIGHTS TYPE E14

341-GK-30 FLOOR LAMP STRUCTURE AND BASE IN L_56 (BLACK MATTE FINISH); DETAILS IN F_14 (POLISHED GOLD FINISH) AND F_15 (SATIN GOLD FINISH). METAL BASE. 4 LIGHTS TYPE E14

FLAIRE

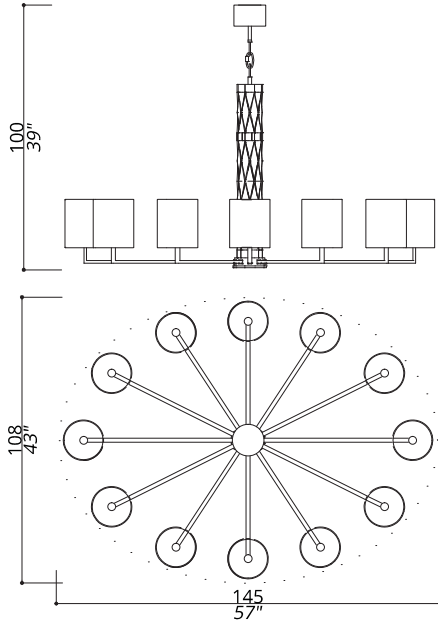

411-BB-22

CHANDELIER

OVAL SHAPED; CENTRAL STRUCTURE COMPOSITION OF SOLID BRASS ELEMENTS. 50 CENTIMETRES OF CHAIN INCLUDED.

STRUCTURE IN F_13 (BURNISHED BRASS FINISH); CONNECTION BOX AND DETAILS IN F_10 (NATURAL BRASS).

12 LIGHTS
TYPE E14

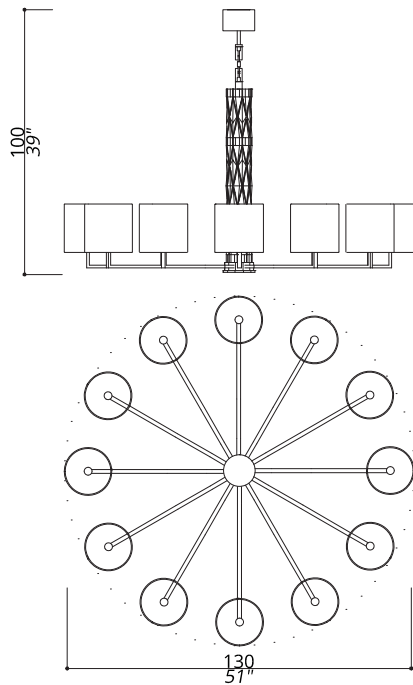

413-BB-22

CHANDELIER

ROUND SHAPED; CENTRAL STRUCTURE COMPOSITION OF SOLID BRASS ELEMENTS. 50 CENTIMETRES OF CHAIN INCLUDED.

STRUCTURE IN F_13 (BURNISHED BRASS FINISH); CONNECTION BOX AND DETAILS IN F_10 (NATURAL BRASS).

12 LIGHTS
TYPE E14

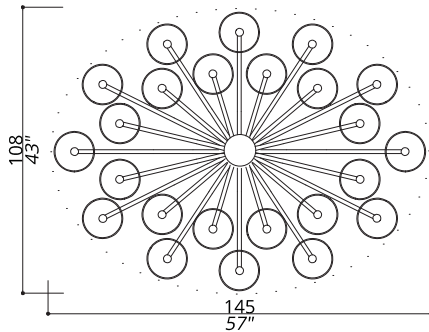
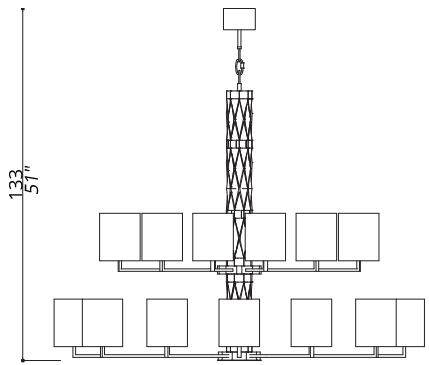

414-BB-24

DOUBLE
CHANDELIER

TWO LAYERS, OVAL SHAPED; CENTRAL STRUCTURE COMPOSITION OF SOLID BRASS ELEMENTS. 50 CENTIMETRES OF CHAIN INCLUDED.

24 LIGHTS
TYPE E14

STRUCTURE IN F_13 (BURNISHED BRASS FINISH); CONNECTION BOX AND DETAILS IN F_10 (NATURAL BRASS).

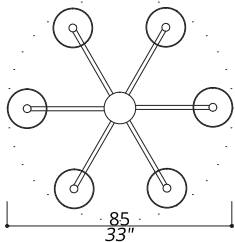
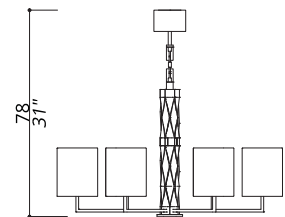

415-BB-22

SUSPENSION

ROUND SHAPED; CENTRAL STRUCTURE COMPOSITION OF SOLID BRASS ELEMENTS. 50 CENTIMETRES OF CHAIN INCLUDED.

6 LIGHTS
TYPE E14

STRUCTURE IN F_13 (BURNISHED BRASS FINISH); CONNECTION BOX AND DETAILS IN F_10 (NATURAL BRASS).

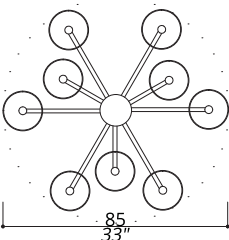
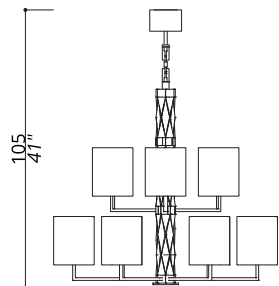

416-BB-22

DOUBLE
SUSPENSION

ROUND SHAPED; CENTRAL STRUCTURE COMPOSITION OF SOLID BRASS ELEMENTS. 50 CENTIMETRES OF CHAIN INCLUDED.

9 LIGHTS
TYPE E14

STRUCTURE IN F_13 (BURNISHED BRASS FINISH); CONNECTION BOX AND DETAILS IN F_10 (NATURAL BRASS).

FLAIRE

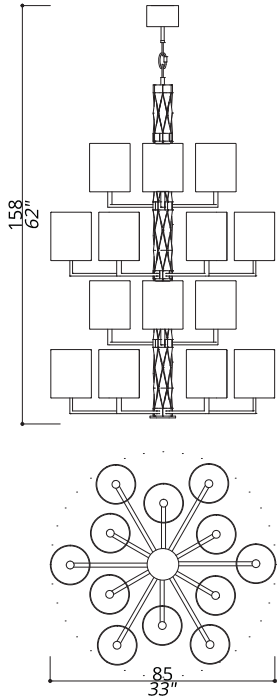

418-BB-22

MODULAR
CHANDELIER

ROUND SHAPED; CENTRAL STRUCTURE
COMPOSITION OF SOLID BRASS ELEMENTS.
50 CENTIMETRES OF CHAIN INCLUDED.

STRUCTURE IN F_13 (BURNISHED BRASS
FINISH); CONNECTION BOX AND DETAILS IN
F_10 (NATURAL BRASS).

18 LIGHTS
TYPE E14

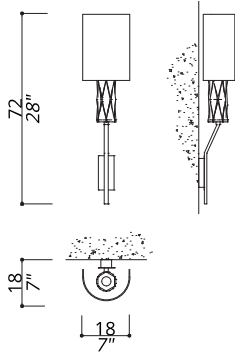

421-BB-22

WALL LAMP

STRUCTURE IN F_13 (BURNISHED BRASS
FINISH); CONNECTION BOX AND DETAILS IN
F_10 (NATURAL BRASS).

1 LIGHT
TYPE E14

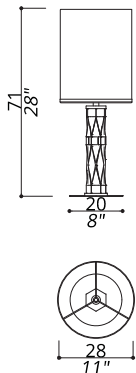

431-BB-22

TABLE LAMP

STRUCTURE AND BASE IN F_13 (BURNISHED
BRASS FINISH); DETAILS IN F_10 (NATURAL
BRASS). METAL BASE.

1 LIGHT
TYPE E27

431-NN-22

TABLE LAMP

STRUCTURE AND BASE IN F_33 (SATIN
NICKEL FINISH); DETAILS IN F_31 (POLISHED
NICKEL FINISH). METAL BASE.

1 LIGHT
TYPE E27

431-RK-25

TABLE LAMP

STRUCTURE AND BASE IN L_56 (BLACK
MATTE FINISH); DETAILS IN F_21 (POLISHED
COPPER FINISH). METAL BASE.

1 LIGHT
TYPE E27

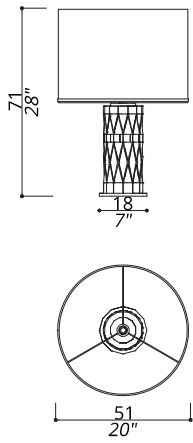

432-BB-22

TABLE LAMP

STRUCTURE AND BASE IN F_13 (BURNISHED BRASS FINISH); DETAILS IN F_10 (NATURAL BRASS). METAL BASE.

1 LIGHT
TYPE E27

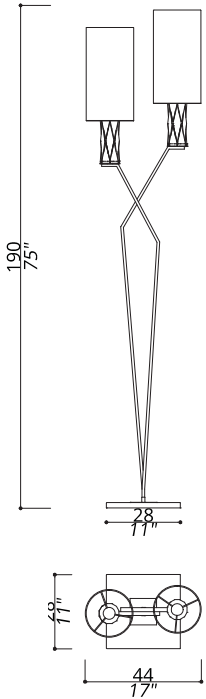

441-RK-25

FLOOR LAMP

STRUCTURE IN L_56 (BLACK MATTE FINISH); DETAILS IN F_21 (POLISHED COPPER FINISH). MARQUINIA MARBLE BASE.

2 LIGHTS
TYPE E14

441-BB-22

FLOOR LAMP

STRUCTURE IN F_13 (BURNISHED BRASS FINISH); DETAILS IN F_10 (NATURAL BRASS). PORTORO MARBLE BASE.

2 LIGHTS
TYPE E14

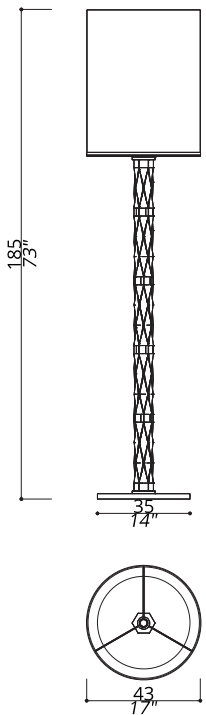

442-BB-22

FLOOR LAMP

STRUCTURE IN F_13 (BURNISHED BRASS FINISH); DETAILS IN F_10 (NATURAL BRASS). PORTORO MARBLE BASE.

1 LIGHT
TYPE E27

TOP

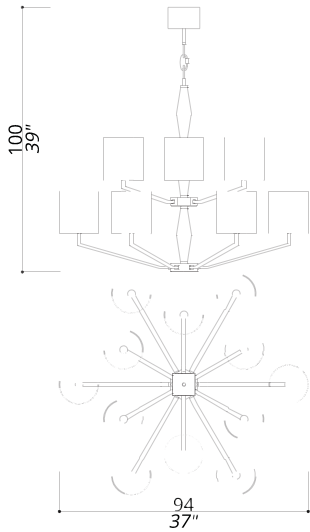

511-GK-24

CHANDELIER

TWO LAYERED CHANDELIER; SOLID ALUMINIUM CENTRAL STRUCTURE. 50 CENTIMETRES OF CHAIN INCLUDED.

12 LIGHTS
TYPE E14

STRUCTURE IN L_56 (BLACK MATTE FINISH); CONNECTION BOX AND DETAILS IN F_15 (SATIN GOLD FINISH).

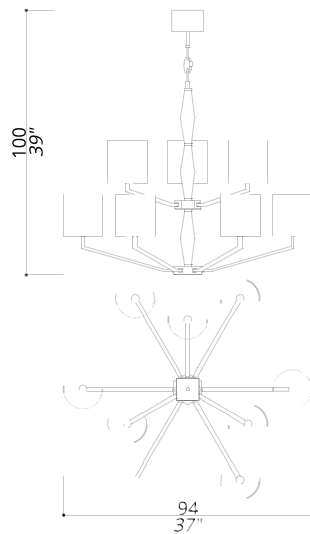

512-GK-24

CHANDELIER

TWO LAYERED CHANDELIER; SOLID ALUMINIUM CENTRAL STRUCTURE. 50 CENTIMETRES OF CHAIN INCLUDED.

9 LIGHTS
TYPE E14

STRUCTURE IN L_56 (BLACK MATTE FINISH); CONNECTION BOX AND DETAILS IN F_15 (SATIN GOLD FINISH).

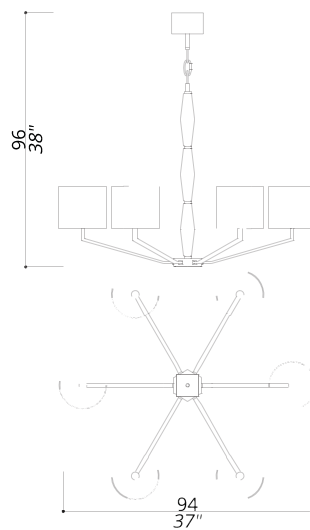

513-GK-24

CHANDELIER

ONE LAYERED CHANDELIER; SOLID ALUMINIUM CENTRAL STRUCTURE. 50 CENTIMETRES OF CHAIN INCLUDED.

6 LIGHTS
TYPE E14

STRUCTURE IN L_56 (BLACK MATTE FINISH); CONNECTION BOX AND DETAILS IN F_15 (SATIN GOLD FINISH).

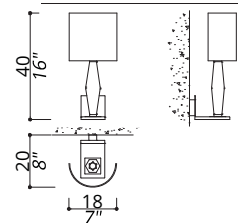

521-GK-24

WALL LAMP

STRUCTURE IN L_56 (BLACK MATTE FINISH); CONNECTION BOX AND DETAILS IN F_15 (SATIN GOLD FINISH).

1 LIGHT
TYPE E14

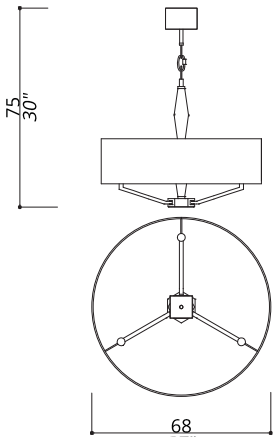

515-GK-24

SUSPENSION

SOLID ALUMINIUM CENTRAL STRUCTURE.
50 CENTIMETRES OF CHAIN INCLUDED.

3 LIGHTS
TYPE E14

STRUCTURE IN L_56 (BLACK MATTE FINISH);
CONNECTION BOX AND DETAILS IN F_15
(SATIN GOLD FINISH).

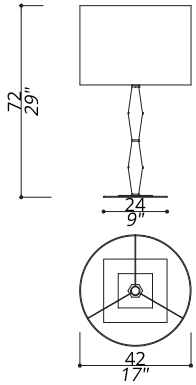

531-GK-24

TABLE LAMP

STRUCTURE IN L_56 (BLACK MATTE FINISH);
BASE AND DETAILS IN F_15 (SATIN GOLD
FINISH). METAL BASE.

1 LIGHT
TYPE E27

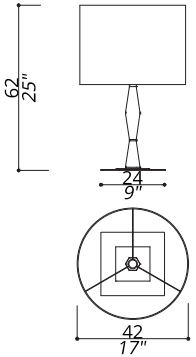

532-GK-24

TABLE LAMP

STRUCTURE IN L_56 (BLACK MATTE FINISH);
BASE AND DETAILS IN F_15 (SATIN GOLD
FINISH). METAL BASE.

1 LIGHT
TYPE E27

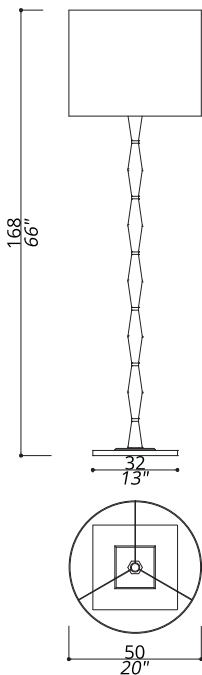

541-GK-24

FLOOR LAMP

STRUCTURE IN L_56 (BLACK MATTE FINISH);
BASE AND DETAILS IN F_15 (SATIN GOLD
FINISH). METAL BASE.

1 LIGHT
TYPE E27

TOP GLASS

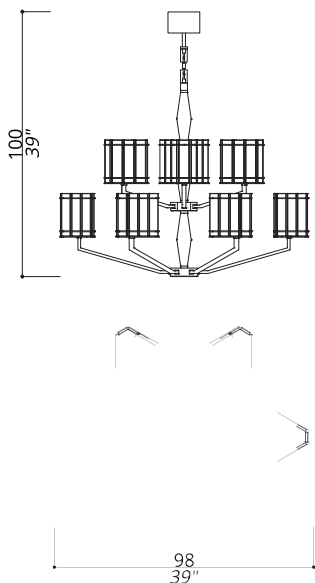

611-GK-X

CHANDELIER

TWO LAYERED CHANDELIER; SOLID ALUMINIUM CENTRAL STRUCTURE. 50 CENTIMETRES OF CHAIN INCLUDED.

12 LIGHTS
TYPE E14

STRUCTURE IN L_56 (BLACK MATTE FINISH); CONNECTION BOX AND DETAILS IN F_15 (SATIN GOLD FINISH).

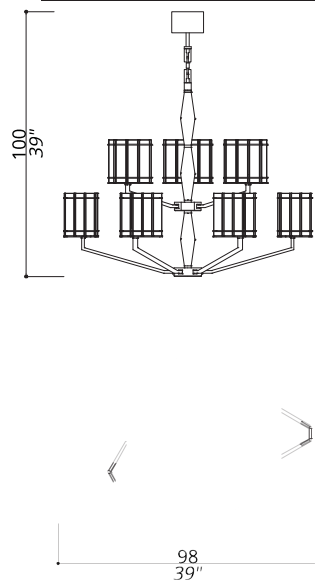

612-GK-X

CHANDELIER

TWO LAYERED CHANDELIER; SOLID ALUMINIUM CENTRAL STRUCTURE. 50 CENTIMETRES OF CHAIN INCLUDED.

9 LIGHTS
TYPE E14

STRUCTURE IN L_56 (BLACK MATTE FINISH); CONNECTION BOX AND DETAILS IN F_15 (SATIN GOLD FINISH).

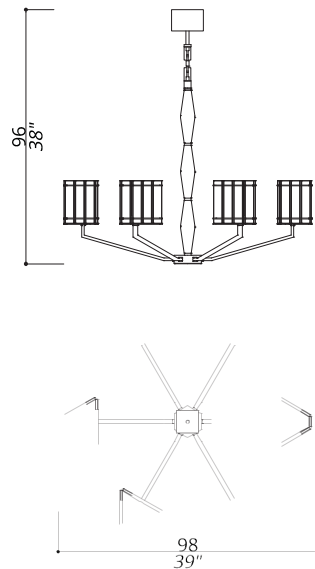

613-GK-X

CHANDELIER

ONE LAYERED CHANDELIER; SOLID ALUMINIUM CENTRAL STRUCTURE. 50 CENTIMETRES OF CHAIN INCLUDED.

6 LIGHTS
TYPE E14

STRUCTURE IN L_56 (BLACK MATTE FINISH); CONNECTION BOX AND DETAILS IN F_15 (SATIN GOLD FINISH).

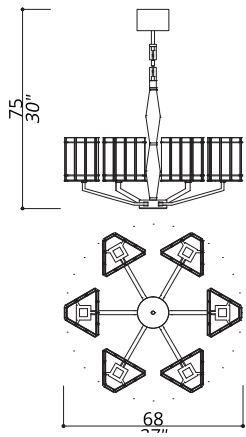

614-GK-X

CHANDELIER

SOLID ALUMINIUM CENTRAL STRUCTURE. 50 CENTIMETRES OF CHAIN INCLUDED.

6 LIGHTS
TYPE E14

STRUCTURE IN L_56 (BLACK MATTE FINISH); CONNECTION BOX AND DETAILS IN F_15 (SATIN GOLD FINISH).

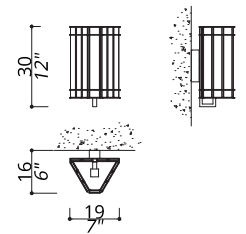

621-GK-X

WALL LAMP

STRUCTURE IN L_56 (BLACK MATTE FINISH); BASE AND DETAILS IN F_15 (SATIN GOLD FINISH). METAL BASE.

1 LIGHT
TYPE E14

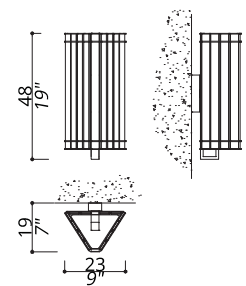

623-GK-X

WALL LAMP

STRUCTURE IN L_56 (BLACK MATTE FINISH); BASE AND DETAILS IN F_15 (SATIN GOLD FINISH). METAL BASE.

2 LIGHTS
TYPE E14

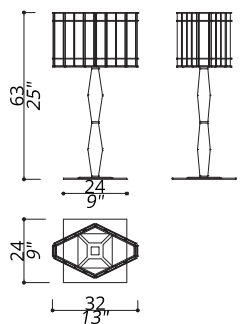

631-GK-24

TABLE LAMP

TWO LAYERED CHANDELIER; SOLID ALUMINIUM CENTRAL STRUCTURE. 50 CENTIMETRES OF CHAIN INCLUDED.

1 LIGHT
TYPE E27

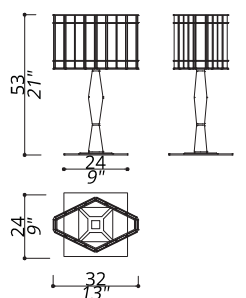

632-GK-24

TABLE LAMP

STRUCTURE IN L_56 (BLACK MATTE FINISH); BASE AND DETAILS IN F_15 (SATIN GOLD FINISH). METAL BASE.

1 LIGHT
TYPE E27

TOP GLASS

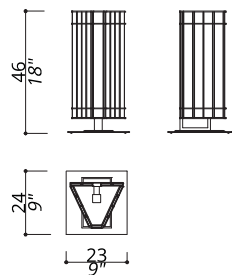

633-GK-X

TABLE LAMP

STRUCTURE IN L_56 (BLACK MATTE FINISH);
BASE AND DETAILS IN F_15 (SATIN GOLD
FINISH). METAL BASE.

2 LIGHTS
TYPE E14

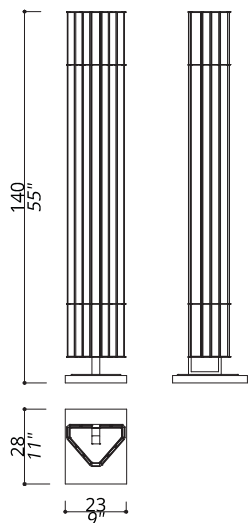

641-GK-X

FLOOR LAMP

STRUCTURE IN L_56 (BLACK MATTE FINISH);
BASE AND DETAILS IN F_15 (SATIN GOLD
FINISH). METAL BASE.

3 LIGHTS
TYPE E14

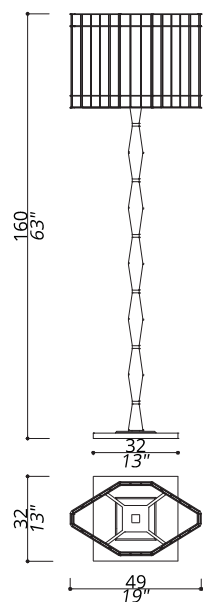

642-GK-X

FLOOR LAMP

STRUCTURE IN L_56 (BLACK MATTE FINISH);
BASE AND DETAILS IN F_15 (SATIN GOLD
FINISH). METAL BASE.

1 LIGHT
TYPE E27

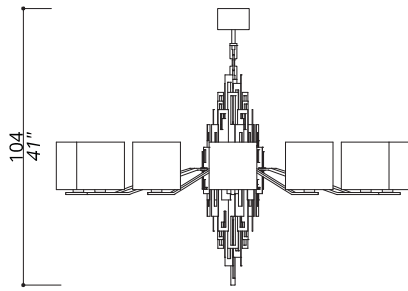

711-BB-11

CHANDELIER

PLAIN & HAMMERED PLATES CENTRAL DESIGN. 50 CENTIMETRES OF CHAIN INCLUDED.

12 LIGHTS
TYPE E14

STRUCTURE IN F_13 (BURNISHED BRASS FINISH); CONNECTION BOX IN F_10 (NATURAL BRASS). DETAILS IN F_13, F_12 (BRUSHED&BURNISHED BRASS) AND F_10.

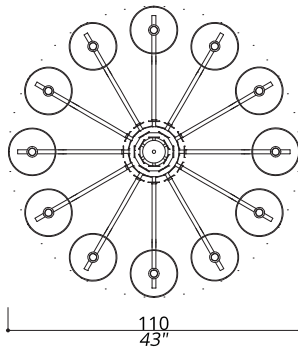

711-NN-33

CHANDELIER

STRUCTURE IN F_41 (POLISHED BLACK NICKEL); CONNECTION BOX IN F_31 (POLISHED NICKEL FINISH). DETAILS IN F_41, F_33 (SATIN NICKEL FINISH) AND F_31.

12 LIGHTS
TYPE E14

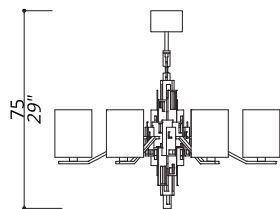

712-BB-11

CHANDELIER

PLAIN & HAMMERED PLATES CENTRAL DESIGN. 50 CENTIMETRES OF CHAIN INCLUDED.

6 LIGHTS
TYPE E14

STRUCTURE IN F_13 (BURNISHED BRASS FINISH); CONNECTION BOX IN F_10 (NATURAL BRASS). DETAILS IN F_13, F_12 (BRUSHED&BURNISHED BRASS) AND F_10.

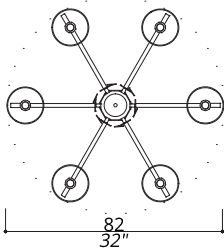

712-NN-33

CHANDELIER

STRUCTURE IN F_41 (POLISHED BLACK NICKEL); CONNECTION BOX IN F_31 (POLISHED NICKEL FINISH). DETAILS IN F_41, F_33 (SATIN NICKEL FINISH) AND F_31.

6 LIGHTS
TYPE E14

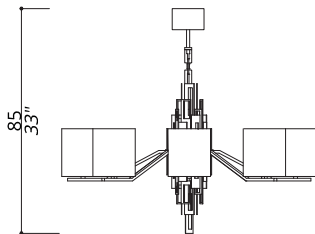

713-BB-11

CHANDELIER

PLAIN & HAMMERED PLATES CENTRAL DESIGN. 50 CENTIMETRES OF CHAIN INCLUDED.

8 LIGHTS
TYPE E14

STRUCTURE IN F_13 (BURNISHED BRASS FINISH); CONNECTION BOX IN F_10 (NATURAL BRASS). DETAILS IN F_13, F_12 (BRUSHED&BURNISHED BRASS) AND F_10.

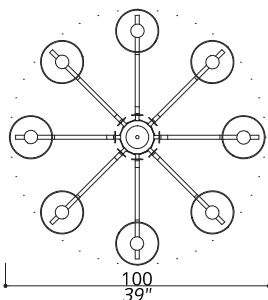

713-NN-33

CHANDELIER

STRUCTURE IN F_41 (POLISHED BLACK NICKEL); CONNECTION BOX IN F_31 (POLISHED NICKEL FINISH). DETAILS IN F_41, F_33 (SATIN NICKEL FINISH) AND F_31.

8 LIGHTS
TYPE E14

GLAM

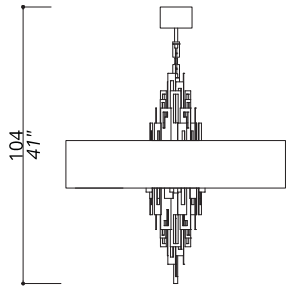

756-BB-11

SUSPENSION

PLAIN & HAMMERED PLATES CENTRAL DESIGN. 50 CENTIMETRES OF CHAIN INCLUDED.

STRUCTURE IN F_13 (BURNISHED BRASS FINISH); CONNECTION BOX IN F_10 (NATURAL BRASS). DETAILS IN F_13, F_12 (BRUSHED&BURNISHED BRASS) AND F_10.

6 LIGHTS
TYPE E14

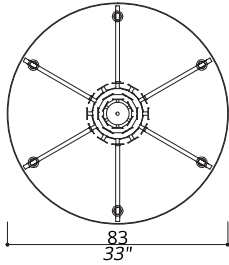

756-NK-07

SUSPENSION

STRUCTURE IN L_56 (BLACK FINISH); DETAILS IN L_56, F_33 (SATIN NICKEL) AND F_31 (POLISHED NICKEL). CONNECTION BOX IN F_31.

6 LIGHTS
TYPE E14

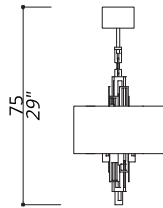

757-BB-11

SUSPENSION

PLAIN & HAMMERED PLATES CENTRAL DESIGN. 50 CENTIMETRES OF CHAIN INCLUDED.

STRUCTURE IN F_13 (BURNISHED BRASS FINISH); CONNECTION BOX IN F_10 (NATURAL BRASS). DETAILS IN F_13, F_12 (BRUSHED&BURNISHED BRASS) AND F_10.

6 LIGHTS
TYPE E14

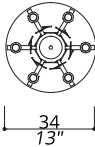

757-NK-07

SUSPENSION

STRUCTURE IN L_56 (BLACK FINISH); DETAILS IN L_56, F_33 (SATIN NICKEL) AND F_31 (POLISHED NICKEL). CONNECTION BOX IN F_31.

6 LIGHTS
TYPE E14

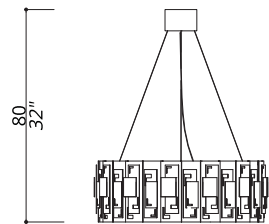

750-BB

SUSPENSION

PLAIN & HAMMERED PLATES DESIGN. 50 CENTIMETRES OF STEEL WIRE INCLUDED.

STRUCTURE AND CONNECTION BOX IN F_13 (BURNISHED BRASS FINISH); DETAILS IN F_12 (BRUSHED&BURNISHED BRASS) AND F_10 (NATURAL BRASS).

6 LIGHTS
TYPE E27

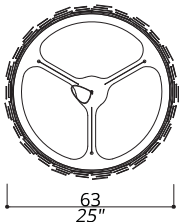

750-NJ

SUSPENSION

STRUCTURE AND CONNECTION BOX IN L_55 (BEIGE FINISH); DETAILS IN L_55, F_33 (SATIN NICKEL) AND F_31 (POLISHED NICKEL).

6 LIGHTS
TYPE E27



751-BB

CEILING LAMP

PLAIN & HAMMERED PLATES DESIGN.

STRUCTURE AND CONNECTION BOX IN F_13 (BURNISHED BRASS FINISH); DETAILS IN F_12 (BRUSHED&BURNISHED BRASS) AND F_10 (NATURAL BRASS).

6 LIGHTS
TYPE E27

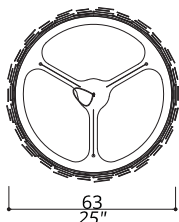

751-NJ

CEILING LAMP

STRUCTURE AND CONNECTION BOX IN L_55 (BEIGE FINISH); DETAILS IN L_55, F_33 (SATIN NICKEL) AND F_31 (POLISHED NICKEL).

6 LIGHTS
TYPE E27

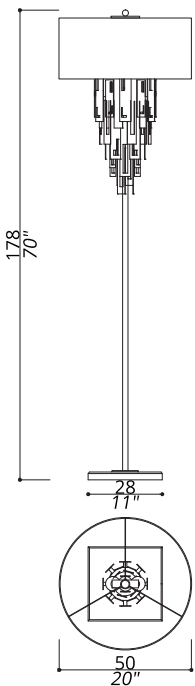
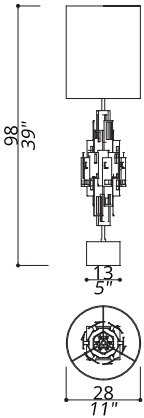
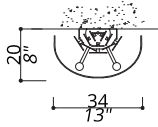
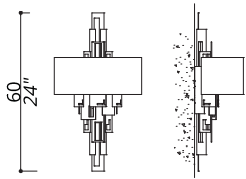

721-BB-11	WALL LAMP	<p>PLAIN & HAMMERED PLATES CENTRAL DESIGN.</p> <p>STRUCTURE AND CONNECTION BOX IN F_10 (NATURAL BRASS). DETAILS IN F_12 (BRUSHED&BURNISHED BRASS) AND F_10.</p>	2 LIGHTS TYPE E14
721-NN-33	WALL LAMP	STRUCTURE AND CONNECTION BOX IN F_33 (SATIN NICKEL FINISH). DETAILS IN F_33 AND F_31 (POLISHED NICKEL FINISH).	2 LIGHTS TYPE E14
731-BB-11	TABLE LAMP	<p>PLAIN & HAMMERED PLATES CENTRAL DESIGN.</p> <p>STRUCTURE IN F_10 (NATURAL BRASS); DETAILS IN F_12 (BRUSHED&BURNISHED BRASS) AND F_10. CALACATTA MARBLE BASE.</p>	1 LIGHT TYPE E27
731-BB-26	TABLE LAMP	STRUCTURE IN F_10 (NATURAL BRASS); DETAILS IN F_12 (BRUSHED&BURNISHED BRASS) AND F_10. PORTORO MARBLE BASE.	1 LIGHT TYPE E27
731-NK-07	TABLE LAMP	STRUCTURE IN L_56 (BLACK FINISH); DETAILS IN L_56, F_33 (SATIN NICKEL FINISH) AND F_31 (POLISHED NICKEL FINISH). MARQUINIA MARBLE BASE.	1 LIGHT TYPE E27
741-BB-11	FLOOR LAMP	<p>PLAIN & HAMMERED PLATES CENTRAL DESIGN.</p> <p>STRUCTURE IN F_10 (NATURAL BRASS); DETAILS IN F_12 (BRUSHED&BURNISHED BRASS) AND F_10. CALACATTA MARBLE BASE.</p>	1 LIGHT TYPE E27
741-BB-26	TABLE LAMP	STRUCTURE IN F_10 (NATURAL BRASS); DETAILS IN F_12 (BRUSHED&BURNISHED BRASS) AND F_10. PORTORO MARBLE BASE.	1 LIGHT TYPE E27
741-NK-07	TABLE LAMP	STRUCTURE IN L_56 (BLACK FINISH); DETAILS IN L_56, F_33 (SATIN NICKEL FINISH) AND F_31 (POLISHED NICKEL FINISH). MARQUINIA MARBLE BASE.	1 LIGHT TYPE E27

TRAPEZE

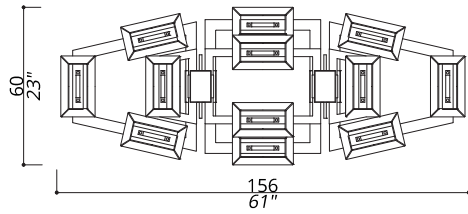
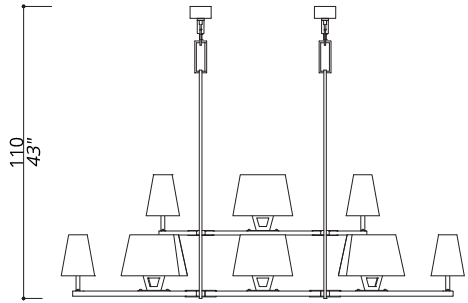

811-NC-04

DOUBLE
CHANDELIER

STRUCTURE IN L_57 (WHITE FINISH);
DETAILS AND CONNECTION BOX IN F_31
(POLISHED NICKEL FINISH).

12 LIGHTS
TYPE E14

811-BB-24

DOUBLE
CHANDELIER

STRUCTURE IN F_13 (BURNISHED BRASS
FINISH); CONNECTION BOX AND DETAILS IN
F_10 (NATURAL BRASS).

12 LIGHTS
TYPE E14

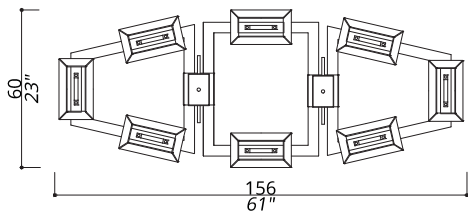
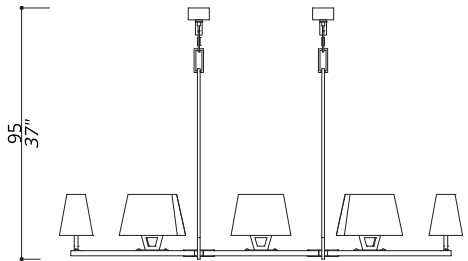

812-NC-04

CHANDELIER

STRUCTURE IN L_57 (WHITE FINISH);
DETAILS AND CONNECTION BOX IN F_31
(POLISHED NICKEL FINISH).

8 LIGHTS
TYPE E14

812-BB-24

CHANDELIER

STRUCTURE IN F_13 (BURNISHED BRASS
FINISH); CONNECTION BOX AND DETAILS IN
F_10 (NATURAL BRASS).

8 LIGHTS
TYPE E14

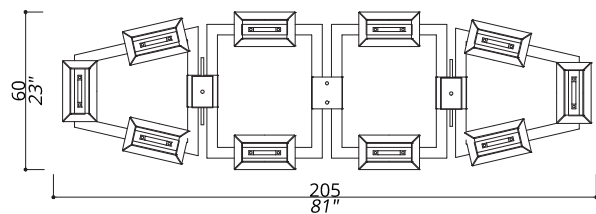
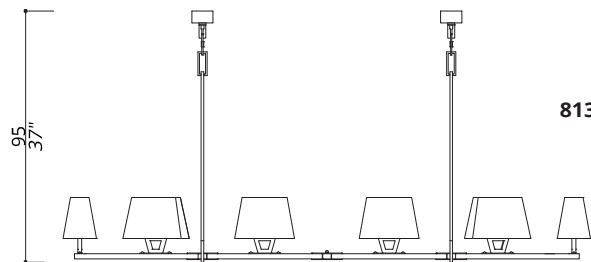

813-NC-04

CHANDELIER

STRUCTURE IN L_57 (WHITE FINISH);
DETAILS AND CONNECTION BOX IN F_31
(POLISHED NICKEL FINISH).

10 LIGHTS
TYPE E14

813-BB-24

CHANDELIER

STRUCTURE IN F_13 (BURNISHED BRASS
FINISH); CONNECTION BOX AND DETAILS IN
F_10 (NATURAL BRASS).

10 LIGHTS
TYPE E14

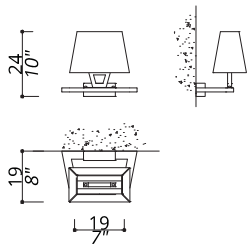

821-NC-04 WALL LAMP STRUCTURE IN L_57 (WHITE FINISH); DETAILS AND CONNECTION BOX IN F_31 (POLISHED NICKEL FINISH). 1 LIGHT TYPE E14

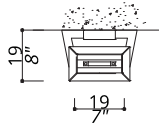

821-BB-24 WALL LAMP STRUCTURE IN F_13 (BURNISHED BRASS FINISH); CONNECTION BOX AND DETAILS IN F_10 (NATURAL BRASS). 1 LIGHT TYPE E14

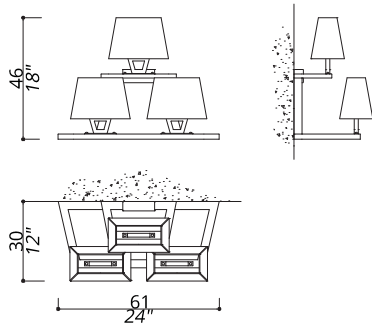

823-NC-04 WALL LAMP STRUCTURE IN L_57 (WHITE FINISH); DETAILS AND CONNECTION BOX IN F_31 (POLISHED NICKEL FINISH). 3 LIGHTS TYPE E14

823-BB-24 WALL LAMP STRUCTURE IN F_13 (BURNISHED BRASS FINISH); CONNECTION BOX AND DETAILS IN F_10 (NATURAL BRASS). 3 LIGHTS TYPE E14

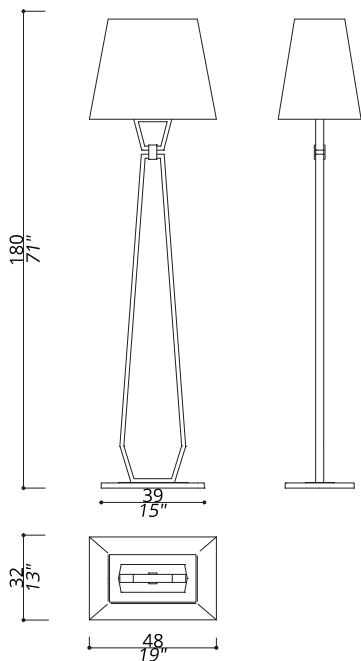

841-NC-04 FLOOR LAMP STRUCTURE IN L_57 (WHITE FINISH); DETAILS AND CONNECTION BOX IN F_31 (POLISHED NICKEL FINISH). 1 LIGHT TYPE E27

841-BB-24 FLOOR LAMP STRUCTURE IN F_13 (BURNISHED BRASS FINISH); CONNECTION BOX AND DETAILS IN F_10 (NATURAL BRASS). 1 LIGHT TYPE E27

SABA

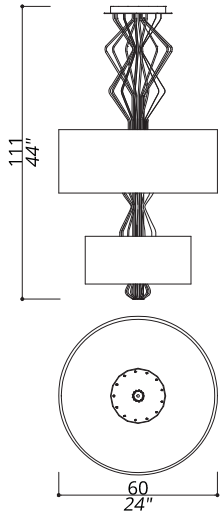

1011-BB-01

DOUBLE
CHANDELIER

TWO LAYERED CHANDELIER.
BRASS STICKS CENTRAL DESIGN.

STRUCTURE IN F_10 (NATURAL BRASS);
CONNECTION BOX AND DETAILS IN F_12
(BRUSHED&BURNISHED BRASS).

6 LIGHTS
TYPE E27

1011-BB-28

DOUBLE
CHANDELIER

STRUCTURE IN F_10 (NATURAL BRASS);
CONNECTION BOX AND DETAILS IN F_12
(BRUSHED&BURNISHED BRASS).

6 LIGHTS
TYPE E27

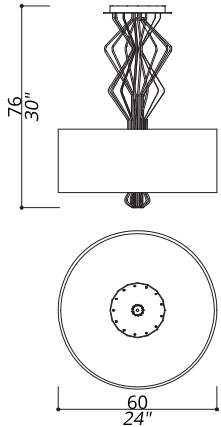

1012-BB-01

CHANDELIER

BRASS STICKS CENTRAL DESIGN.

STRUCTURE IN F_10 (NATURAL BRASS);
CONNECTION BOX AND DETAILS IN F_12
(BRUSHED&BURNISHED BRASS).

3 LIGHTS
TYPE E27

1012-BB-28

CHANDELIER

STRUCTURE IN F_10 (NATURAL BRASS);
CONNECTION BOX AND DETAILS IN F_12
(BRUSHED&BURNISHED BRASS).

3 LIGHTS
TYPE E27

1012-NN-23

CHANDELIER

STRUCTURE IN F_31 (POLISHED NICKEL
FINISH); CONNECTION BOX AND DETAILS
IN F_33 (SATIN NICKEL FINISH).

3 LIGHTS
TYPE E27

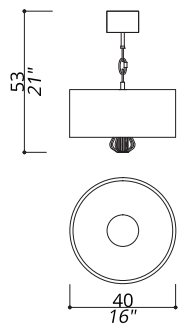

1015-BB-01

CHANDELIER

BRASS STICKS DESIGN.

STRUCTURE AND CONNECTION BOX
IN F_10 (NATURAL BRASS).

3 LIGHTS
TYPE E27

1015-BB-28

CHANDELIER

STRUCTURE AND CONNECTION BOX
IN F_10 (NATURAL BRASS).

3 LIGHTS
TYPE E27

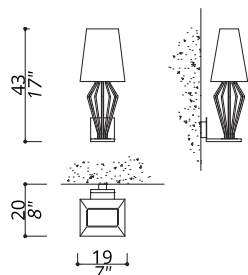

1021-BB-22

WALL LAMP

STRUCTURE AND CONNECTION BOX
IN F_10 (NATURAL BRASS).

1 LIGHT
TYPE E14

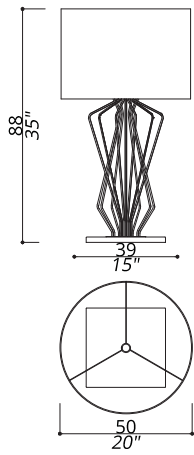

1031-BB-01	TABLE LAMP	BRASS STICKS CENTRAL DESIGN. STRUCTURE IN F_10 (NATURAL BRASS); DETAILS AND BASE IN F_13 (BURNISHED BRASS FINISH). METAL BASE.	1 LIGHT TYPE E27
-------------------	------------	---	---------------------

1031-BB-28	TABLE LAMP	STRUCTURE IN F_10 (NATURAL BRASS); DETAILS AND BASE IN F_13 (BURNISHED BRASS FINISH). METAL BASE.	1 LIGHT TYPE E27
-------------------	------------	---	---------------------

1031-NN-23	TABLE LAMP	STRUCTURE IN F_31 (POLISHED NICKEL FINISH); BASE AND DETAILS IN F_33 (SATIN NICKEL FINISH). METAL BASE.	1 LIGHT TYPE E27
-------------------	------------	---	---------------------

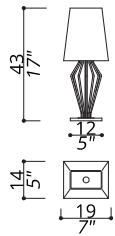

1032-BB-22	TABLE LAMP	BRASS STICKS CENTRAL DESIGN. STRUCTURE IN F_10 (NATURAL BRASS); DETAILS AND BASE IN F_13 (BURNISHED BRASS FINISH). METAL BASE.	1 LIGHT TYPE E14
-------------------	------------	---	---------------------

1032-NN-23	TABLE LAMP	STRUCTURE IN F_31 (POLISHED NICKEL FINISH); BASE AND DETAILS IN F_33 (SATIN NICKEL FINISH). METAL BASE.	1 LIGHT TYPE E14
-------------------	------------	---	---------------------

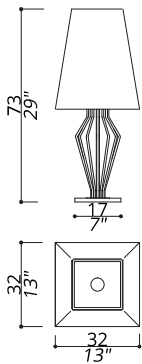

1033-BB-22	TABLE LAMP	BRASS STICKS CENTRAL DESIGN. STRUCTURE IN F_10 (NATURAL BRASS); DETAILS AND BASE IN F_13 (BURNISHED BRASS FINISH). METAL BASE.	1 LIGHT TYPE E27
-------------------	------------	---	---------------------

1033-NN-23	TABLE LAMP	STRUCTURE IN F_31 (POLISHED NICKEL FINISH); BASE AND DETAILS IN F_33 (SATIN NICKEL FINISH). METAL BASE.	1 LIGHT TYPE E27
-------------------	------------	---	---------------------

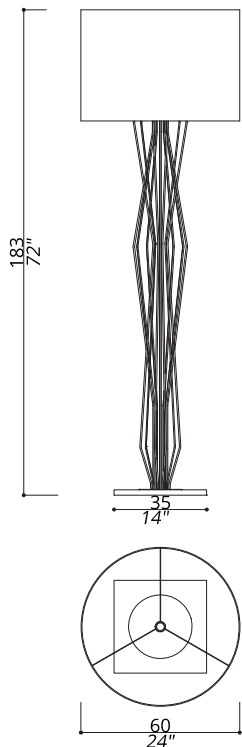

1041-BB-01	FLOOR LAMP	BRASS STICKS CENTRAL DESIGN. STRUCTURE IN F_10 (NATURAL BRASS); DETAILS AND BASE IN F_13 (BURNISHED BRASS FINISH). METAL BASE.	1 LIGHT TYPE E27
-------------------	------------	---	---------------------

1041-BB-28	FLOOR LAMP	STRUCTURE IN F_10 (NATURAL BRASS); DETAILS AND BASE IN F_13 (BURNISHED BRASS FINISH). METAL BASE.	1 LIGHT TYPE E27
-------------------	------------	---	---------------------

1041-NN-24	FLOOR LAMP	STRUCTURE IN F_41 (POLISHED BLACK NICKEL) AND F_31 (POLISHED NICKEL); BASE IN F_33 (SATIN NICKEL). METAL BASE.	1 LIGHT TYPE E27
-------------------	------------	--	---------------------

FLOW

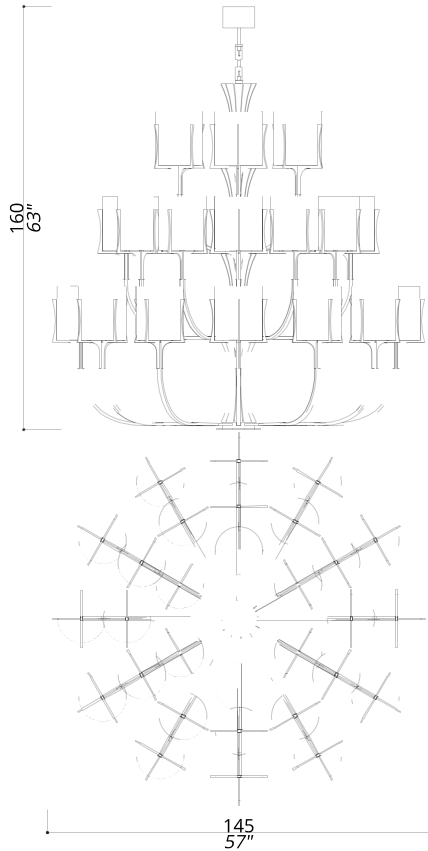

1111-GW-24

CHANDELIER

THREE LAYERED CHANDELIER;
EBONY WOOD STICKS CENTRAL DESIGN.
50 CENTIMETRES OF CHAIN INCLUDED.

30 LIGHTS
TYPE E14

STRUCTURE AND CONNECTION BOX IN F_15
(SATIN GOLD FINISH); CENTRAL STRUCTURE
IN EBONY WOOD IN SATIN FINISH.

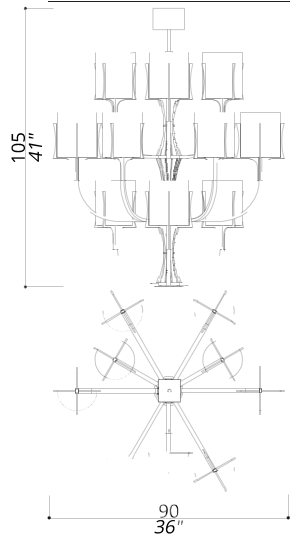

1112-GW-24

MODULAR
CHANDELIER

THREE LAYERED MODULAR CHANDELIER;
EBONY WOOD STICKS CENTRAL DESIGN.
50 CENTIMETRES OF CHAIN INCLUDED.

12 LIGHTS
TYPE E14

STRUCTURE AND CONNECTION BOX IN F_15
(SATIN GOLD FINISH); CENTRAL STRUCTURE
IN EBONY WOOD IN SATIN FINISH.

1112-NW-24

MODULAR
CHANDELIER

STRUCTURE AND CONNECTION BOX IN F_33
(SATIN NICKEL FINISH); CENTRAL STRUCTURE
IN EBONY WOOD IN SATIN FINISH.

12 LIGHTS
TYPE E14

1112-NW-S

MODULAR
CHANDELIER

STRUCTURE AND CONNECTION BOX IN F_33
(SATIN NICKEL FINISH); CENTRAL STRUCTURE
IN EBONY WOOD IN SATIN FINISH.

12 LIGHTS
TYPE E14

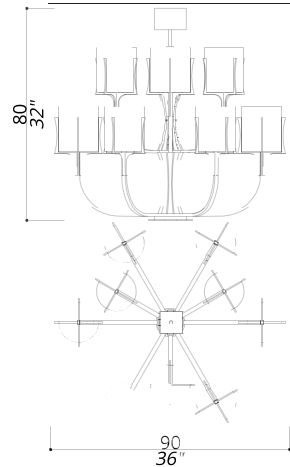

1113-GW-24

MODULAR
CHANDELIER

TWO LAYERED MODULAR CHANDELIER;
EBONY WOOD STICKS CENTRAL DESIGN.
50 CENTIMETRES OF CHAIN INCLUDED.

9 LIGHTS
TYPE E14

STRUCTURE AND CONNECTION BOX IN F_15
(SATIN GOLD FINISH); CENTRAL STRUCTURE
IN EBONY WOOD IN SATIN FINISH.

1113-NW-24

MODULAR
CHANDELIER

STRUCTURE AND CONNECTION BOX IN F_33
(SATIN NICKEL FINISH); CENTRAL STRUCTURE
IN EBONY WOOD IN SATIN FINISH.

9 LIGHTS
TYPE E14

1113-NW-S

MODULAR
CHANDELIER

STRUCTURE AND CONNECTION BOX IN F_33
(SATIN NICKEL FINISH); CENTRAL STRUCTURE
IN EBONY WOOD IN SATIN FINISH.

9 LIGHTS
TYPE E14

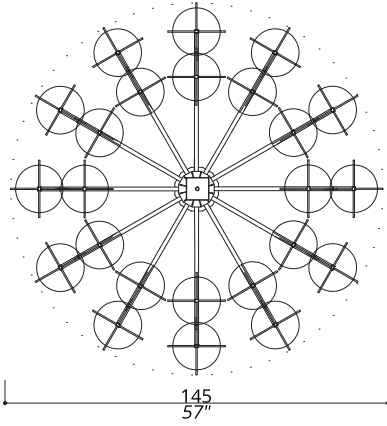
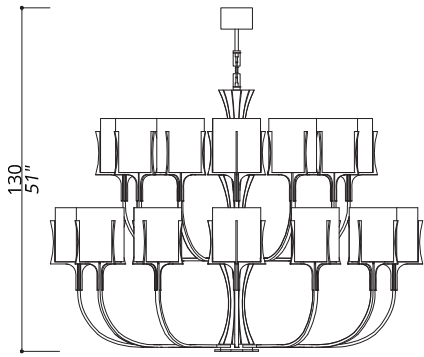

1115-GW-24 CHANDELIER TWO LAYERED CHANDELIER; EBONY WOOD STICKS CENTRAL DESIGN. 50 CENTIMETRES OF CHAIN INCLUDED. 24 LIGHTS TYPE E14

STRUCTURE AND CONNECTION BOX IN F_15 (SATIN GOLD FINISH); CENTRAL STRUCTURE IN EBONY WOOD IN SATIN FINISH.

1115-NW-24 CHANDELIER STRUCTURE AND CONNECTION BOX IN F_33 (SATIN NICKEL FINISH); CENTRAL STRUCTURE IN EBONY WOOD IN SATIN FINISH. 24 LIGHTS TYPE E14

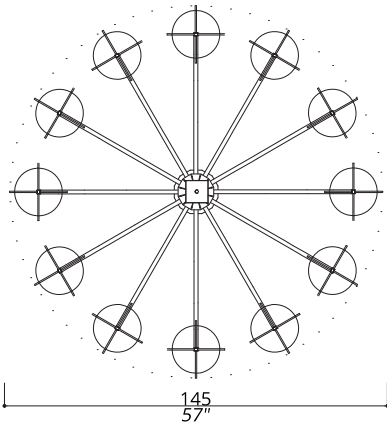
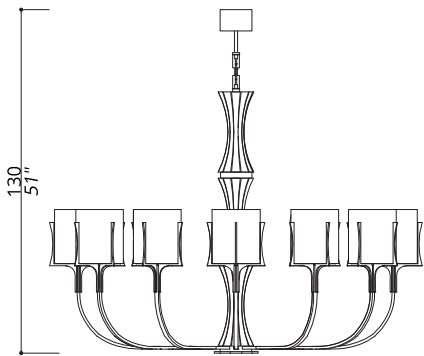

1116-GW-24 CHANDELIER EBONY WOOD STICKS CENTRAL DESIGN. 50 CENTIMETRES OF CHAIN INCLUDED. 12 LIGHTS TYPE E14

STRUCTURE AND CONNECTION BOX IN F_15 (SATIN GOLD FINISH); CENTRAL STRUCTURE IN EBONY WOOD IN SATIN FINISH.

1116-NW-24 CHANDELIER STRUCTURE AND CONNECTION BOX IN F_33 (SATIN NICKEL FINISH); CENTRAL STRUCTURE IN EBONY WOOD IN SATIN FINISH. 12 LIGHTS TYPE E14

FLOW

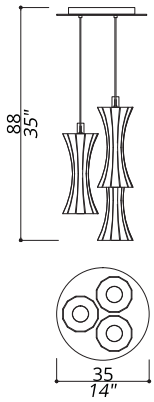

1150-GW	TRIPLE SUSPENSION	COMPOSITION OF 3 FIXTURES. 50 CENTIMETRES OF STEEL WIRE INCLUDED. CONNECTION BOX IN F_15 (SATIN GOLD FINISH); CENTRAL STRUCTURE IN EBONY WOOD IN SATIN FINISH.	3 LIGHTS GU10 LED INCLUDED
----------------	-------------------	--	----------------------------------

1150-NW	TRIPLE SUSPENSION	CONNECTION BOX IN F_33 (SATIN NICKEL FINISH); CENTRAL STRUCTURE IN EBONY WOOD IN SATIN FINISH.	3 LIGHTS GU10 LED INCLUDED
----------------	-------------------	--	----------------------------------

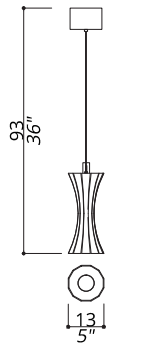

1151-GW	SINGLE SUSPENSION	SINGLE FIXTURE. 50 CENTIMETRES OF STEEL WIRE INCLUDED. CONNECTION BOX IN F_15 (SATIN GOLD FINISH); CENTRAL STRUCTURE IN EBONY WOOD IN SATIN FINISH.	1 LIGHT GU10 LED INCLUDED
----------------	-------------------	---	---------------------------------

1151-NW	SINGLE SUSPENSION	CONNECTION BOX IN F_33 (SATIN NICKEL FINISH); CENTRAL STRUCTURE IN EBONY WOOD IN SATIN FINISH.	1 LIGHT GU10 LED INCLUDED
----------------	-------------------	--	---------------------------------

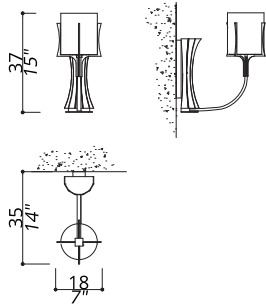

1121-GW-24	WALL LAMP	CONNECTION BOX IN F_15 (SATIN GOLD FINISH); CENTRAL STRUCTURE IN EBONY WOOD IN SATIN FINISH.	1 LIGHT TYPE E14
-------------------	-----------	--	---------------------

1121-NW-24	WALL LAMP	CONNECTION BOX IN F_33 (SATIN NICKEL FINISH); CENTRAL STRUCTURE IN EBONY WOOD IN SATIN FINISH.	1 LIGHT TYPE E14
-------------------	-----------	--	---------------------

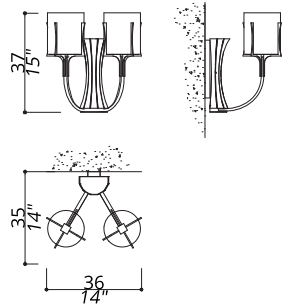

1122-GW-24	WALL LAMP	CONNECTION BOX IN F_15 (SATIN GOLD FINISH); CENTRAL STRUCTURE IN EBONY WOOD IN SATIN FINISH.	2 LIGHTS TYPE E14
-------------------	-----------	--	----------------------

1122-NW-24	WALL LAMP	CONNECTION BOX IN F_33 (SATIN NICKEL FINISH); CENTRAL STRUCTURE IN EBONY WOOD IN SATIN FINISH.	2 LIGHTS TYPE E14
-------------------	-----------	--	----------------------

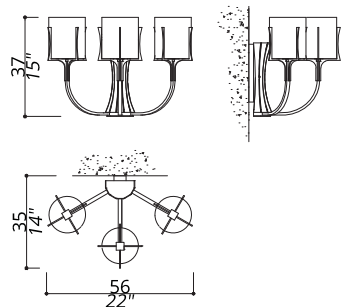

1123-GW-24	WALL LAMP	CONNECTION BOX IN F_15 (SATIN GOLD FINISH); CENTRAL STRUCTURE IN EBONY WOOD IN SATIN FINISH.	3 LIGHTS TYPE E14
-------------------	-----------	--	----------------------

1123-NW-24	WALL LAMP	CONNECTION BOX IN F_33 (SATIN NICKEL FINISH); CENTRAL STRUCTURE IN EBONY WOOD IN SATIN FINISH.	3 LIGHTS TYPE E14
-------------------	-----------	--	----------------------

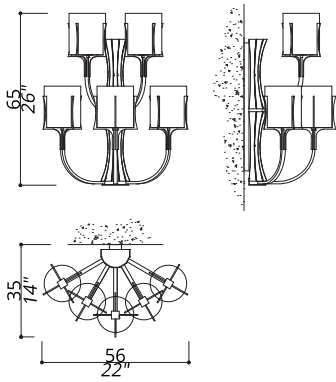

1124-GW-24 WALL LAMP CONNECTION BOX IN F_15 (SATIN GOLD FINISH); CENTRAL STRUCTURE IN EBONY WOOD IN SATIN FINISH. 5 LIGHTS TYPE E14

1124-NW-24 WALL LAMP CONNECTION BOX IN F_33 (SATIN NICKEL FINISH); CENTRAL STRUCTURE IN EBONY WOOD IN SATIN FINISH. 5 LIGHTS TYPE E14

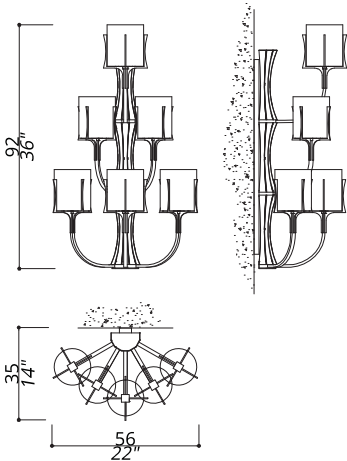

1125-GW-24 WALL LAMP CONNECTION BOX IN F_15 (SATIN GOLD FINISH); CENTRAL STRUCTURE IN EBONY WOOD IN SATIN FINISH. 6 LIGHTS TYPE E14

1125-NW-24 WALL LAMP CONNECTION BOX IN F_33 (SATIN NICKEL FINISH); CENTRAL STRUCTURE IN EBONY WOOD IN SATIN FINISH. 6 LIGHTS TYPE E14

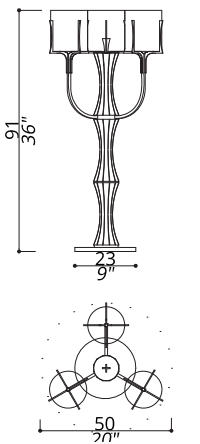

1131-GW-24 TABLE LAMP STRUCTURE AND BASE IN F_15 (SATIN GOLD FINISH); CENTRAL STRUCTURE IN EBONY WOOD IN SATIN FINISH. METAL BASE. 3 LIGHTS TYPE E14

1131-NW-24 TABLE LAMP STRUCTURE AND BASE IN F_33 (SATIN NICKEL FINISH); CENTRAL STRUCTURE IN EBONY WOOD IN SATIN FINISH. METAL BASE. 3 LIGHTS TYPE E14

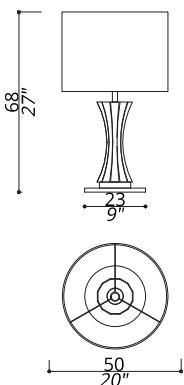

1132-GW-24 TABLE LAMP STRUCTURE AND BASE IN F_15 (SATIN GOLD FINISH); CENTRAL STRUCTURE IN EBONY WOOD IN SATIN FINISH. METAL BASE. 1 LIGHT TYPE E27

1132-NW-24 TABLE LAMP STRUCTURE AND BASE IN F_33 (SATIN NICKEL FINISH); CENTRAL STRUCTURE IN EBONY WOOD IN SATIN FINISH. METAL BASE. 1 LIGHT TYPE E27

FLOW

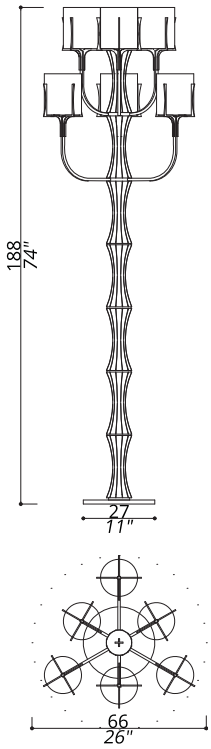

1141-GW-24 FLOOR LAMP STRUCTURE AND BASE IN F_15 (SATIN GOLD FINISH); CENTRAL STRUCTURE IN EBONY WOOD IN SATIN FINISH. METAL BASE. 6 LIGHTS TYPE E14

1141-NW-24 FLOOR LAMP STRUCTURE AND BASE IN F_33 (SATIN NICKEL FINISH); CENTRAL STRUCTURE IN EBONY WOOD IN SATIN FINISH. METAL BASE. 6 LIGHTS TYPE E14

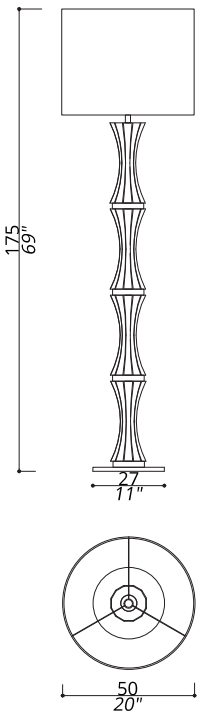

1142-GW-24 FLOOR LAMP STRUCTURE AND BASE IN F_15 (SATIN GOLD FINISH); CENTRAL STRUCTURE IN EBONY WOOD IN SATIN FINISH. METAL BASE. 1 LIGHT TYPE E27

1142-NW-24 FLOOR LAMP STRUCTURE AND BASE IN F_33 (SATIN NICKEL FINISH); CENTRAL STRUCTURE IN EBONY WOOD IN SATIN FINISH. METAL BASE. 1 LIGHT TYPE E27

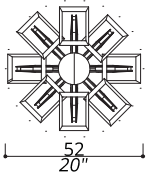
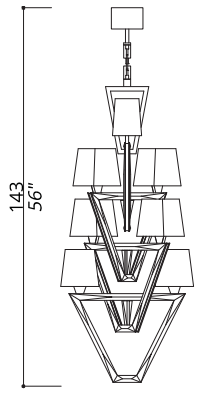

1211-GK-28

CHANDELIER

SOLID ALUMINIUM 3D DESIGN ON BOTH SIDES OF CENTRAL STRUCTURE. 50 CENTIMETRES OF CHAIN INCLUDED.

STRUCTURE IN L_56 (BLACK MATTE FINISH); DETAILS IN F_15 (SATIN GOLD FINISH).

8 LIGHTS
TYPE E14

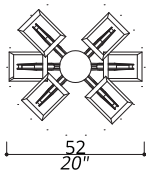
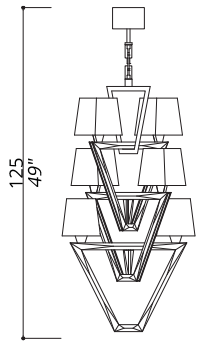

1212-GK-28

CHANDELIER

SOLID ALUMINIUM 3D DESIGN ON BOTH SIDES OF CENTRAL STRUCTURE. 50 CENTIMETRES OF CHAIN INCLUDED.

STRUCTURE IN F_15 (SATIN GOLD FINISH); DETAILS IN L_56 (BLACK MATTE FINISH).

8 LIGHTS
TYPE E14

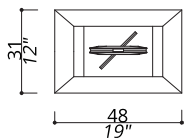
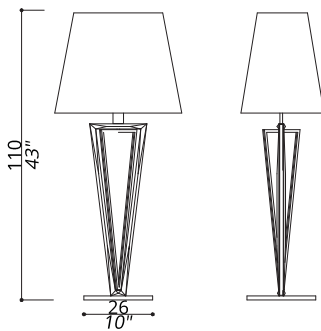

1231-GK-28

TABLE LAMP

SOLID ALUMINIUM 3D DESIGN ON BOTH SIDES OF CENTRAL STRUCTURE.

STRUCTURE IN L_56 (BLACK MATTE FINISH); DETAILS IN F_15 (SATIN GOLD FINISH).

1 LIGHT
TYPE E27

NEW SHADE

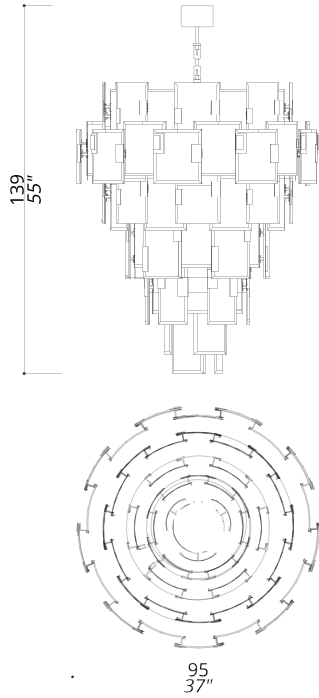

1311-RB-35

CHANDELIER

6 LAYERS SUSPENSION.
50 CENTIMETRES OF CHAIN INCLUDED.

STRUCTURE, CONNECTION BOX, FRAMINGS
AND DETAILS IN F_21 (POLISHED COPPER
FINISH) AND F_13 (BURNISHED COPPER).

42 LIGHTS
TYPE G9 LED

SHADE

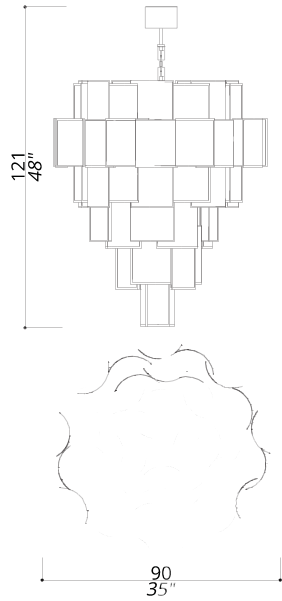

1411-GG-08

CHANDELIER

6 LAYERS SUSPENSION.
50 CENTIMETRES OF CHAIN INCLUDED.

STRUCTURE, CONNECTION BOX, FRAMINGS
AND DETAILS IN F_15 (SATIN GOLD FINISH).

28 LIGHTS
TYPE G9 LED

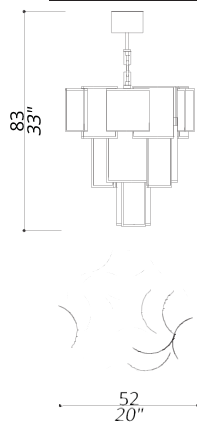

1412-GG-08

CHANDELIER

STRUCTURE, CONNECTION BOX, FRAMINGS
AND DETAILS IN F_15 (SATIN GOLD FINISH).

5 LIGHTS
TYPE G9 LED

1412-NN-35

CHANDELIER

STRUCTURE, CONNECTION BOX,
FRAMINGS AND DETAILS IN F_31
(POLISHED NICKEL FINISH).

5 LIGHTS
TYPE G9 LED

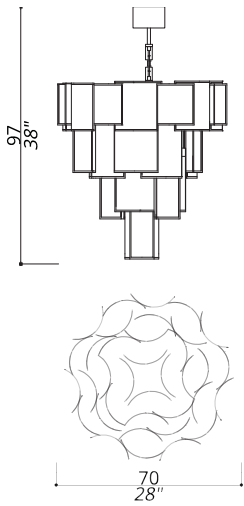

1413-GG-08

CHANDELIER

4 LAYERS SUSPENSION.
50 CENTIMETRES OF CHAIN INCLUDED.

STRUCTURE, CONNECTION BOX, FRAMINGS
AND DETAILS IN F_15 (SATIN GOLD FINISH).

12 LIGHTS
TYPE G9 LED

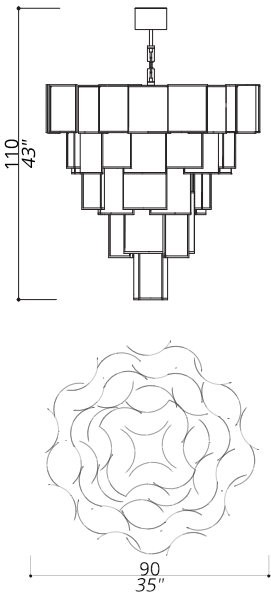

1414-GG-08

CHANDELIER

5 LAYERS SUSPENSION.
50 CENTIMETRES OF CHAIN INCLUDED.

STRUCTURE, CONNECTION BOX, FRAMINGS
AND DETAILS IN F_15 (SATIN GOLD FINISH).

21 LIGHTS
TYPE G9 LED

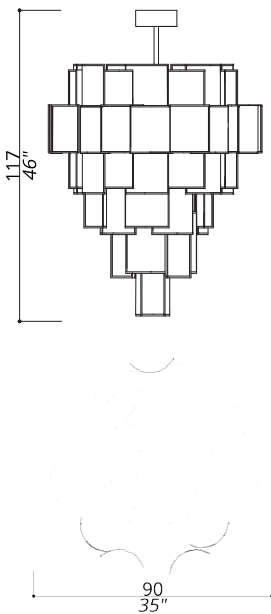

1450-GG-08

CEILING LAMP

6 LAYERS SUSPENSION.

STRUCTURE, CONNECTION BOX, FRAMINGS
AND DETAILS IN F_15 (SATIN GOLD FINISH).

28 LIGHTS
TYPE G9 LED

SHADE

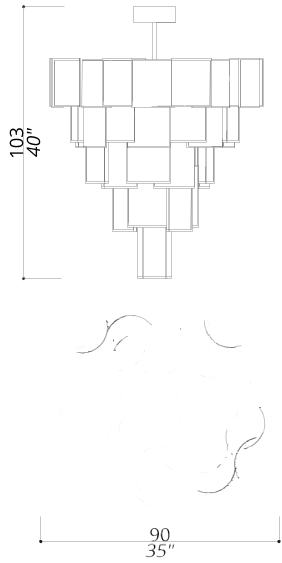

1451-GG-08

CEILING LAMP

5 LAYERS SUSPENSION.
STRUCTURE, CONNECTION BOX, FRAMINGS
AND DETAILS IN F_15 (SATIN GOLD FINISH).

21 LIGHTS
TYPE G9 LED

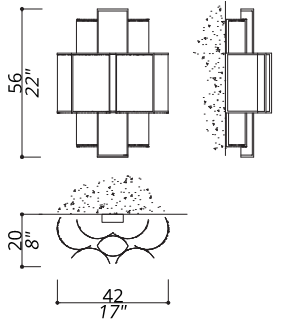

1422-GG-08

WALL LAMP

STRUCTURE, CONNECTION BOX, FRAMINGS
AND DETAILS IN F_15 (SATIN GOLD FINISH).

4 LIGHTS
TYPE G9 LED

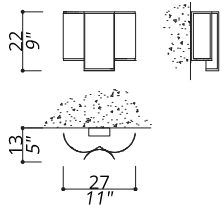

1423-GG-08

WALL LAMP

STRUCTURE, CONNECTION BOX, FRAMINGS
AND DETAILS IN F_15 (SATIN GOLD FINISH).

3 LIGHTS
TYPE G9 LED



1442-GG-08

FLOOR LAMP

STRUCTURE, CONNECTION BOX, FRAMINGS
AND DETAILS IN F_15 (SATIN GOLD FINISH).

8 LIGHTS
TYPE G9 LED

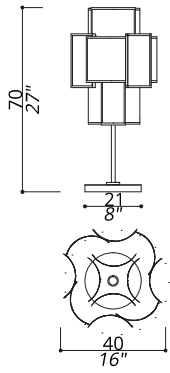

1431-GG-08

TABLE LAMP

STRUCTURE, CONNECTION BOX, FRAMINGS AND DETAILS IN F_15 (SATIN GOLD FINISH).

8 LIGHTS
TYPE G9 LED

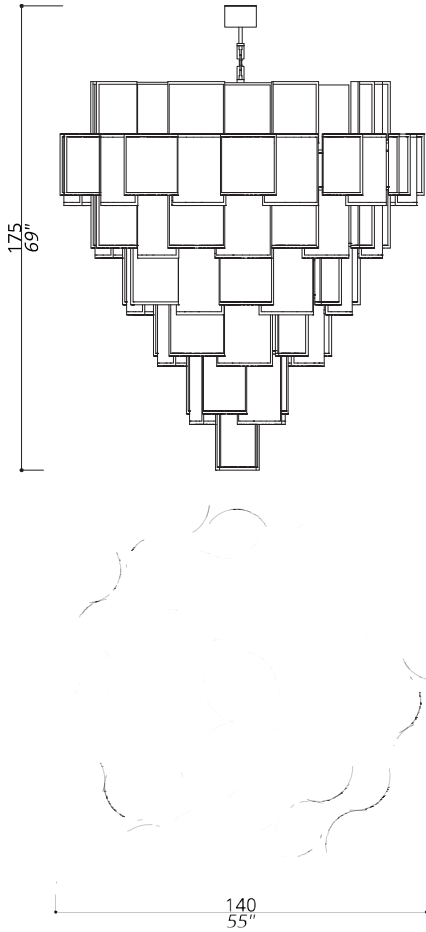

1415-GG-08

MAXI
CHANDELIER

7 LAYERS SUSPENSION.
50 CENTIMETRES OF CHAIN INCLUDED.
STRUCTURE, CONNECTION BOX, FRAMINGS
AND DETAILS IN F_15 (SATIN GOLD FINISH).

41 LIGHTS
TYPE G9 LED

1415-NN-22

MAXI
CHANDELIER

STRUCTURE, CONNECTION BOX,
FRAMINGS AND DETAILS IN F_31
(POLISHED NICKEL FINISH).

41 LIGHTS
TYPE G9 LED

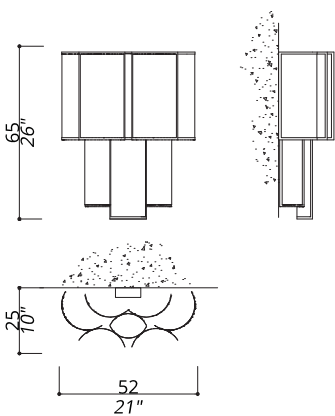

1421-GG-08

MAXI WALL
LAMP

STRUCTURE, CONNECTION BOX, FRAMINGS
AND DETAILS IN F_15 (SATIN GOLD FINISH).

8 LIGHTS
TYPE G9 LED

1421-NN-22

MAXI WALL
LAMP

STRUCTURE, CONNECTION BOX,
FRAMINGS AND DETAILS IN F_31
(POLISHED NICKEL FINISH).

8 LIGHTS
TYPE G9 LED

MARBLE FLAIR

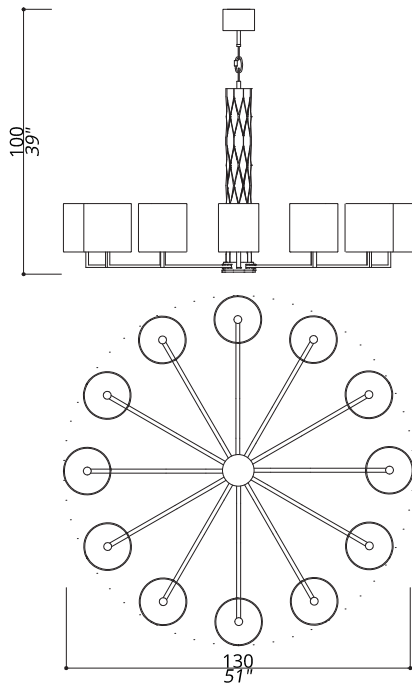

1613-BN-35

CHANDELIER

ROUND SHAPE CHANDELIER; MARBLE INLAYS. 50 CENTIMETRES OF CHAIN INCLUDED.

STRUCTURE IN F_13 (BURNISHED BRASS FINISH); CONNECTION BOX AND DETAILS IN F_31 (POLISHED NICKEL FINISH). CARRARA MARBLE INLAYS.

12 LIGHTS
TYPE E14

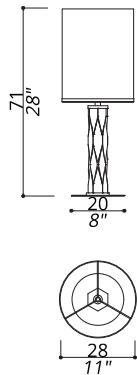

1631-BN-35

TABLE LAMP

MARBLE INLAYS.

STRUCTURE IN F_13 (BURNISHED BRASS FINISH); BASE AND DETAILS IN F_31 (POLISHED NICKEL FINISH). CARRARA MARBLE INLAYS. METAL BASE.

1 LIGHT
TYPE E27

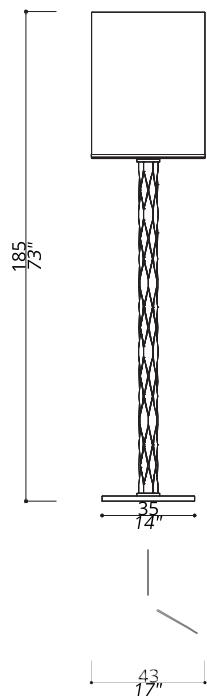

1641-BN-35

FLOOR LAMP

MARBLE INLAYS.

STRUCTURE IN F_13 (BURNISHED BRASS FINISH); DETAILS IN F_31 (POLISHED NICKEL FINISH). CARRARA MARBLE INLAYS AND BASE.

1 LIGHT
TYPE E27

NEW FLOW

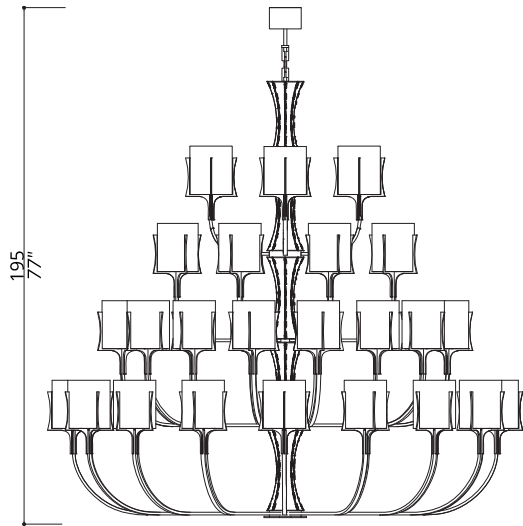

2111-GK-24

CHANDELIER

4 LAYERS CHANDELIER; LEATHER INLAYS.
50 CENTIMETRES OF CHAIN INCLUDED.
STRUCTURE AND CONNECTION BOX IN
F_10 (NATURAL BRASS) AND F_15 (SATIN
GOLD FINISH); BLACK LEATHER INLAYS

44 LIGHTS
TYPE E14

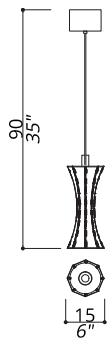
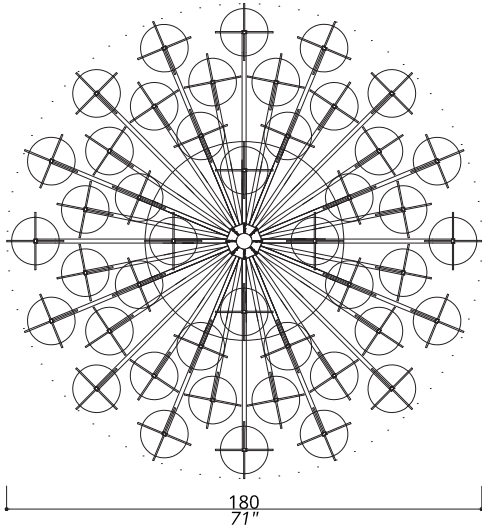

2151-GK

SUSPENSION

50 CENTIMETRES OF STEEL WIRE INCLUDED.
STRUCTURE IN F_10 (NATURAL BRASS)
AND F_15 (SATIN GOLD FINISH);
BLACK LEATHER INLAYS

1 LIGHT TYPE
GU10 LED
INCLUDED

NEW FLOW

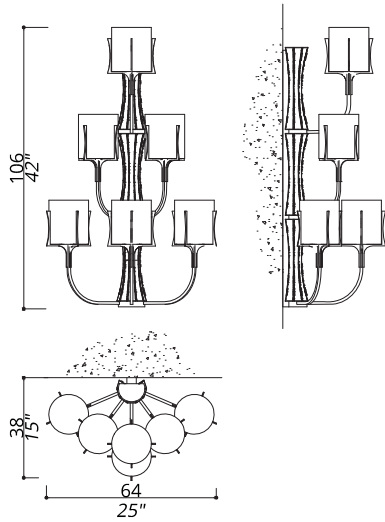

2125-GK-24

WALL LAMP

STRUCTURE AND CONNECTION BOX IN F_10 (NATURAL BRASS) AND F_15 (SATIN GOLD FINISH); BLACK LEATHER INLAYS

6 LIGHTS
TYPE E14

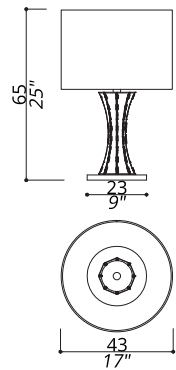

2131-GK-24

TABLE LAMP

STRUCTURE IN F_10 (NATURAL BRASS) AND F_15 (SATIN GOLD FINISH); BLACK LEATHER INLAYS. METAL BASE

1 LIGHT
TYPE E27

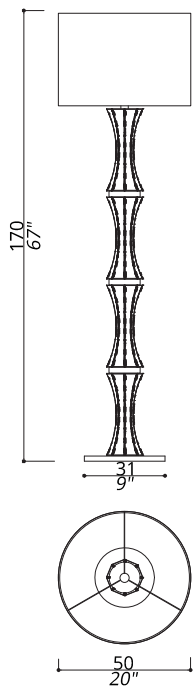

2141-GK-24

FLOOR LAMP

STRUCTURE IN F_10 (NATURAL BRASS) AND F_15 (SATIN GOLD FINISH); BLACK LEATHER INLAYS. METAL BASE

1 LIGHT
TYPE E27

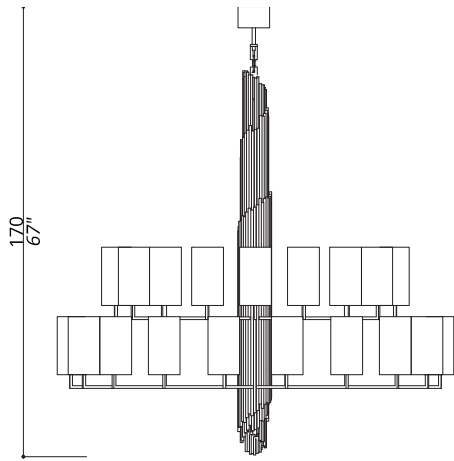

2811-BB-41

CHANDELIER

2 LAYERS CHANDELIER. CENTRAL STRUCTURE OF SOLID BRASS STICKS. 50 CENTIMETRES OF CHAIN INCLUDED.

36 LIGHTS
TYPE E14

STRUCTURE AND CONNECTION BOX IN F_10 (NATURAL BRASS) AND F_13 (BURNISHED BRASS FINISH)

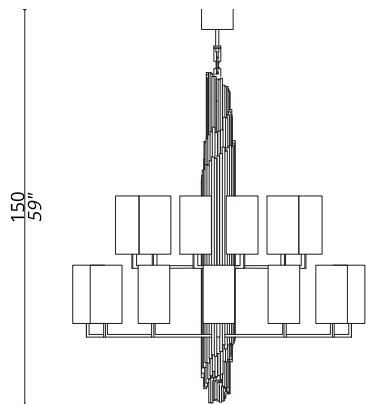
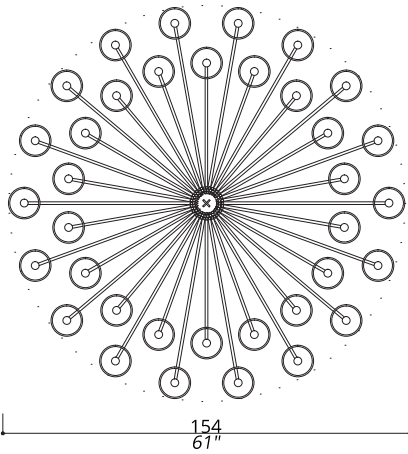

2812-BB-41

CHANDELIER

2 LAYERS CHANDELIER. CENTRAL STRUCTURE OF SOLID BRASS STICKS. 50 CENTIMETRES OF CHAIN INCLUDED.

24 LIGHTS
TYPE E14

STRUCTURE AND CONNECTION BOX IN F_10 (NATURAL BRASS) AND F_13 (BURNISHED BRASS FINISH)

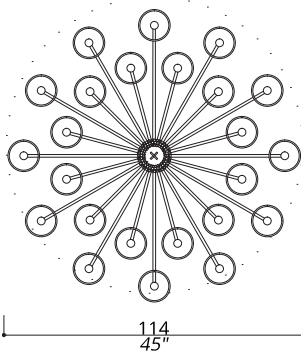

SHINE

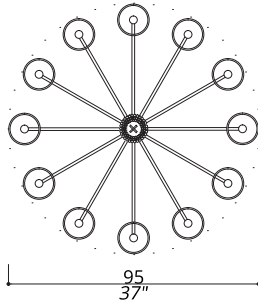
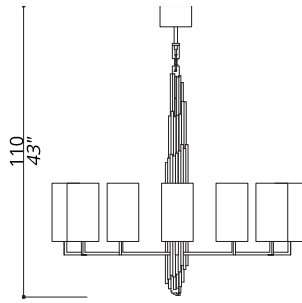

2813-BB-41

CHANDELIER

CENTRAL STRUCTURE OF SOLID BRASS STICKS. 50 CENTIMETRES OF CHAIN INCLUDED.

12 LIGHTS
TYPE E14

STRUCTURE AND CONNECTION BOX IN F_10 (NATURAL BRASS) AND F_13 (BURNISHED BRASS FINISH)

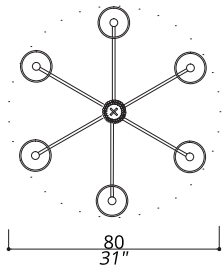
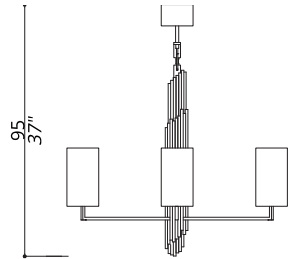

2814-BB-41

CHANDELIER

CENTRAL STRUCTURE OF SOLID BRASS STICKS. 50 CENTIMETRES OF CHAIN INCLUDED.

6 LIGHTS
TYPE E14

STRUCTURE AND CONNECTION BOX IN F_10 (NATURAL BRASS) AND F_13 (BURNISHED BRASS FINISH)

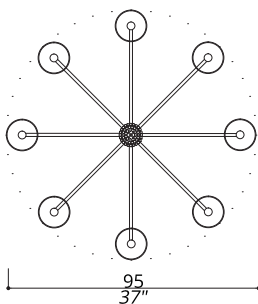
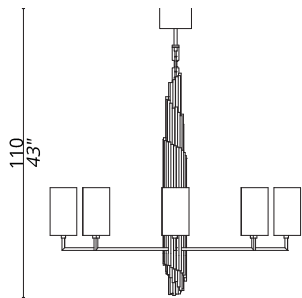

2817-BB-41

CHANDELIER

CENTRAL STRUCTURE OF SOLID BRASS STICKS. 50 CENTIMETRES OF CHAIN INCLUDED.

8 LIGHTS
TYPE E14

STRUCTURE AND CONNECTION BOX IN F_10 (NATURAL BRASS) AND F_13 (BURNISHED BRASS FINISH)

2817-NN-41

CHANDELIER

STRUCTURE AND CONNECTION BOX IN F_31 (POLISHED NICKEL FINISH) AND F_33 (SATIN NICKEL FINISH)

8 LIGHTS
TYPE E14

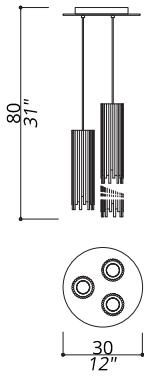

2815-BB	SUSPENSION	STRUCTURE AND CONNECTION BOX IN F_10 (NATURAL BRASS) AND F_13 (BURNISHED BRASS FINISH)	3 LED LIGHTS INCLUDED
2815-NN	SUSPENSION	STRUCTURE AND CONNECTION BOX IN F_31 (POLISHED NICKEL FINISH) AND F_33 (SATIN NICKEL FINISH)	3 LED LIGHTS INCLUDED

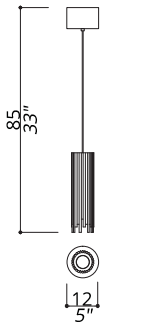

2816-BB	SUSPENSION	STRUCTURE AND CONNECTION BOX IN F_10 (NATURAL BRASS) AND F_13 (BURNISHED BRASS FINISH)	1 LED LIGHT INCLUDED
2816-NN	SUSPENSION	STRUCTURE AND CONNECTION BOX IN F_31 (POLISHED NICKEL FINISH) AND F_33 (SATIN NICKEL FINISH)	1 LED LIGHT INCLUDED

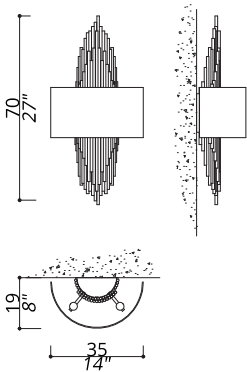

2822-BB-41	WALL LAMP	STRUCTURE AND CONNECTION BOX IN F_10 (NATURAL BRASS) AND F_13 (BURNISHED BRASS FINISH)	2 LIGHTS TYPE E14
-------------------	-----------	--	-------------------

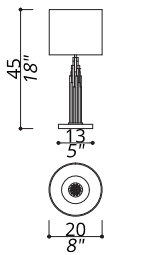

2831-BB-41	TABLE LAMP	STRUCTURE AND CONNECTION BOX IN F_10 (NATURAL BRASS) AND F_13 (BURNISHED BRASS FINISH). METAL BASE	1 LIGHT TYPE E14
-------------------	------------	--	------------------

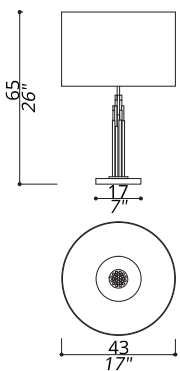

2833-BB-41	TABLE LAMP	STRUCTURE AND CONNECTION BOX IN F_10 (NATURAL BRASS) AND F_13 (BURNISHED BRASS FINISH). METAL BASE	1 LIGHT TYPE E27
2833-NN-41	TABLE LAMP	STRUCTURE AND CONNECTION BOX IN F_31 (POLISHED NICKEL FINISH) AND F_33 (SATIN NICKEL FINISH). METAL BASE	1 LIGHT TYPE E27

SHINE

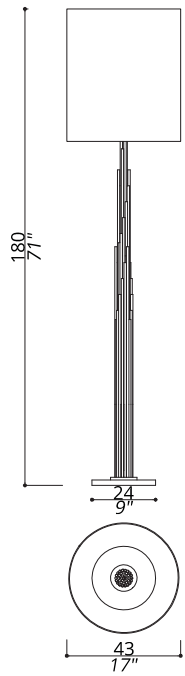

2841-BB-41

FLOOR LAMP

STRUCTURE AND CONNECTION BOX IN F_10 (NATURAL BRASS) AND F_13 (BURNISHED BRASS FINISH). METAL BASE

1 LIGHT
TYPE E27

ETEREA

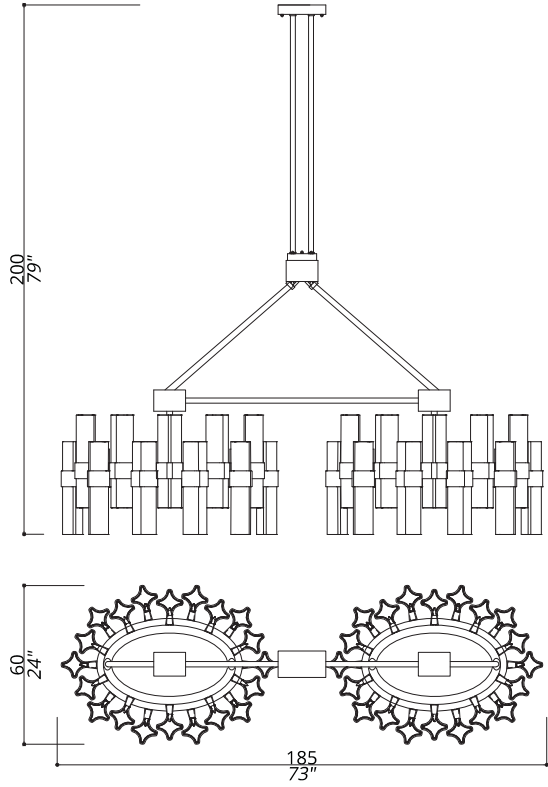

3111-GG-TC

DOUBLE
CHANDELIER

DOUBLE OVAL COMPOSITION.

STRUCTURE IN F_16 (POLISHED LIGHT GOLD
FINISH); GRAY LEATHER UPHOLSTERINGS

80 LIGHTS
TYPE G9 LED

3111-NN-TC

DOUBLE
CHANDELIER

STRUCTURE IN F_31 (NICKEL FINISH);
GRAY LEATHER UPHOLSTERINGS

80 LIGHTS
TYPE G9 LED

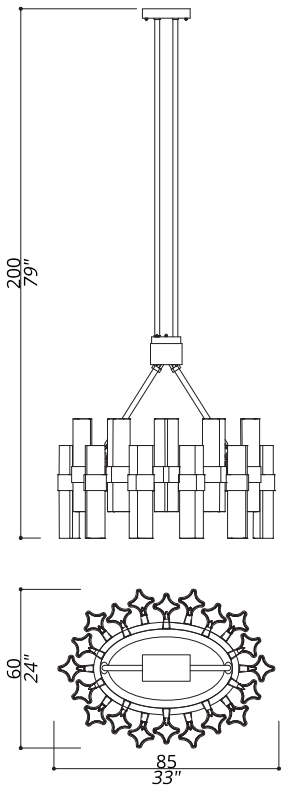

3112-GG-TC

CHANDELIER

OVAL COMPOSITION.

STRUCTURE IN F_16 (POLISHED LIGHT GOLD
FINISH); GRAY LEATHER UPHOLSTERINGS

40 LIGHTS
TYPE G9 LED

3112-NN-TC

CHANDELIER

STRUCTURE IN F_31 (NICKEL FINISH);
GRAY LEATHER UPHOLSTERINGS

40 LIGHTS
TYPE G9 LED

ETEREA

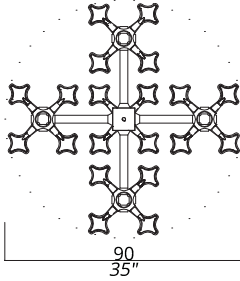
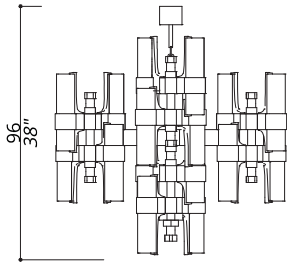

3116-GG-TC	CHANDELIER	LIGHTS COMPOSITION. 50 CENTIMETRES OF CHAIN INCLUDED. STRUCTURE IN F_16 (POLISHED LIGHT GOLD FINISH); GRAY LEATHER UPHOLSTERINGS	40 LIGHTS TYPE G9 LED
-------------------	------------	---	--------------------------

3116-NN-TC	CHANDELIER	STRUCTURE IN F_31 (NICKEL FINISH); GRAY LEATHER UPHOLSTERINGS	40 LIGHTS TYPE G9 LED
-------------------	------------	---	--------------------------

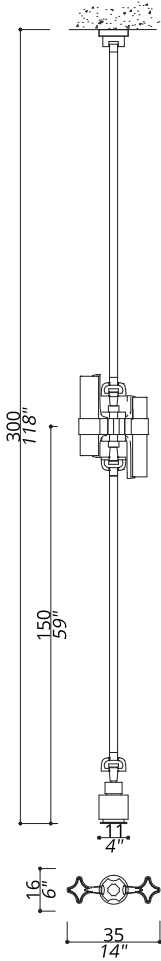

3151-GG-TC	FLOOR TO CEILING FIXTURE	STRUCTURE IN F_16 (POLISHED LIGHT GOLD FINISH); GRAY LEATHER UPHOLSTERINGS	4 LIGHTS TYPE G9 LED
-------------------	--------------------------	--	-------------------------

3151-NN-TC	FLOOR TO CEILING FIXTURE	STRUCTURE IN F_31 (NICKEL FINISH); GRAY LEATHER UPHOLSTERINGS	4 LIGHTS TYPE G9 LED
-------------------	--------------------------	---	-------------------------

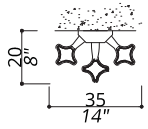
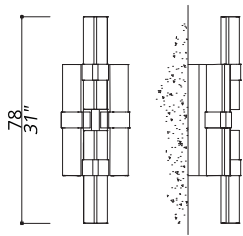

3121-GG-TC WALL LAMP STRUCTURE IN F_16 (POLISHED LIGHT GOLD FINISH) 8 LIGHTS TYPE G9 LED

3121-NN-TC WALL LAMP STRUCTURE IN F_31 (NICKEL FINISH) 8 LIGHTS TYPE G9 LED

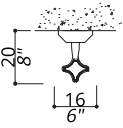
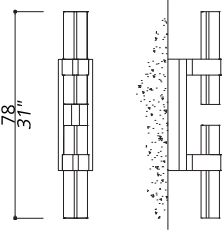

3122-GG-TC WALL LAMP STRUCTURE IN F_16 (POLISHED LIGHT GOLD FINISH) 4 LIGHTS TYPE G9 LED

3122-NN-TC WALL LAMP STRUCTURE IN F_31 (NICKEL FINISH) 4 LIGHTS TYPE G9 LED

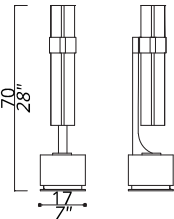

3131-GG-TC TABLE LAMP STRUCTURE IN F_16 (POLISHED LIGHT GOLD FINISH); GRAY LEATHER UPHOLSTERINGS. METAL BASE 2 LIGHTS TYPE G9 LED

3131-NN-TC TABLE LAMP STRUCTURE IN F_31 (NICKEL FINISH); GRAY LEATHER UPHOLSTERINGS. METAL BASE 2 LIGHTS TYPE G9 LED

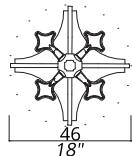
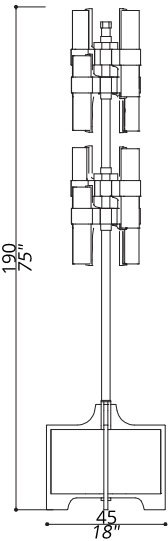

3141-GG-TC FLOOR LAMP STRUCTURE IN F_16 (POLISHED LIGHT GOLD FINISH); GRAY LEATHER UPHOLSTERINGS. BARDIGLIO MARBLE BASE. 16 LIGHTS TYPE G9 LED

3141-NN-TC FLOOR LAMP STRUCTURE IN F_31 (NICKEL FINISH); GRAY LEATHER UPHOLSTERINGS. BARDIGLIO MARBLE BASE. 16 LIGHTS TYPE G9 LED

SOAVE

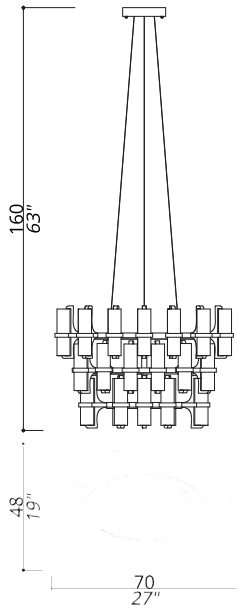

3211-RR-TC	CHANDELIER	<p>OVAL STRUCTURE. 50 CENTIMETRES OF STEEL WIRE INCLUDED.</p> <p>STRUCTURE AND CONNECTION BOX IN F_21 (POLISHED COPPER FINISH)</p>	36 LIGHTS TYPE G9 LED
-------------------	------------	--	--------------------------

3211-GG-TC	CHANDELIER	STRUCTURE AND CONNECTION BOX IN F_16 (LIGHT GOLD FINISH)	36 LIGHTS TYPE G9 LED
-------------------	------------	--	--------------------------

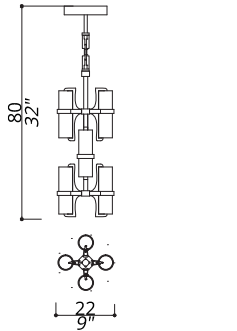

3215-RR-TC	SUSPENSION	<p>50 CENTIMETRES OF CHAIN INCLUDED.</p> <p>STRUCTURE AND CONNECTION BOX IN F_21 (POLISHED COPPER FINISH)</p>	6 LIGHTS TYPE G9 LED
-------------------	------------	---	-------------------------

3215-GG-TC	CHANDELIER	STRUCTURE AND CONNECTION BOX IN F_16 (LIGHT GOLD FINISH)	6 LIGHTS TYPE G9 LED
-------------------	------------	--	-------------------------

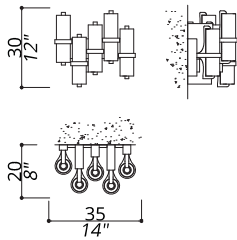

3221-RR-TC	WALL LAMP	STRUCTURE AND CONNECTION BOX IN F_21 (POLISHED COPPER FINISH)	5 LIGHTS TYPE G9 LED
-------------------	-----------	---	-------------------------

3221-GG-TC	WALL LAMP	STRUCTURE AND CONNECTION BOX IN F_16 (LIGHT GOLD FINISH)	5 LIGHTS TYPE G9 LED
-------------------	-----------	--	-------------------------

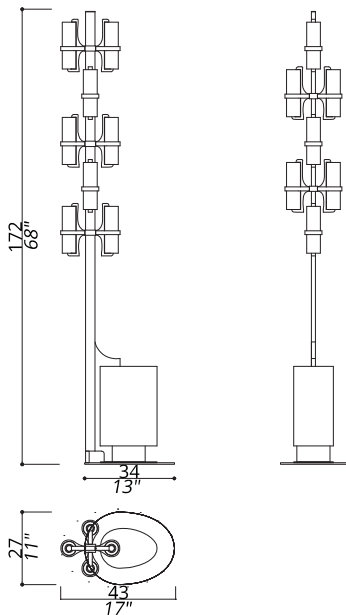

3221-RR-TC	FLOOR LAMP	STRUCTURE IN F_21 (POLISHED COPPER FINISH). BARDIGLIO MARBLE BASE	10 LIGHTS TYPE G9 LED
-------------------	------------	---	--------------------------

3221-GG-TC	FLOOR LAMP	STRUCTURE IN F_16 (LIGHT GOLD FINISH). BARDIGLIO MARBLE BASE	10 LIGHTS TYPE G9 LED
-------------------	------------	--	--------------------------

ANIMA

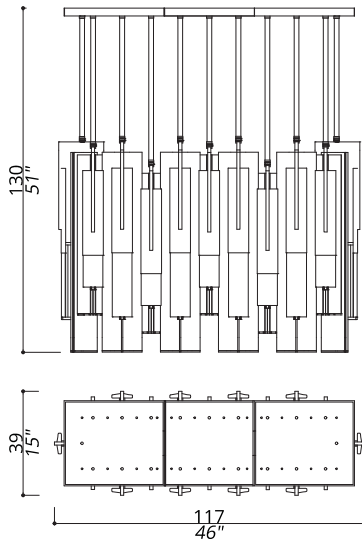

3311-DN-AC	CHANDELIER	20 ELEMENTS SUSPENSION. STRUCTURE IN WALNUT WOOD; CONNECTION BOX AND DETAILS IN F_41 (DARK NICKEL FINISH)	40 LED STRIP LIGHTS
-------------------	------------	--	------------------------

3311-GG-FC	CHANDELIER	STRUCTURE IN WALNUT WOOD; CONNECTION BOX AND DETAILS IN F_16 (LIGHT GOLD FINISH)	40 LED STRIP LIGHTS
-------------------	------------	--	------------------------

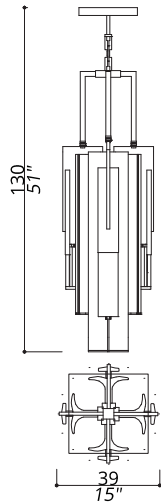

3315-DN-AC	CHANDELIER	4 ELEMENTS SUSPENSION. 50 CENTIMETRES OF CHAIN INCLUDED. STRUCTURE IN WALNUT WOOD; CONNECTION BOX AND DETAILS IN F_41 (DARK NICKEL FINISH)	8 LED STRIP LIGHTS
-------------------	------------	--	-----------------------

3315-GG-FC	CHANDELIER	STRUCTURE IN WALNUT WOOD; CONNECTION BOX AND DETAILS IN F_16 (LIGHT GOLD FINISH)	8 LED STRIP LIGHTS
-------------------	------------	--	-----------------------

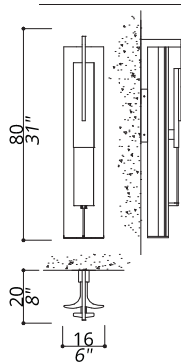

3321-DN-AC	WALL LAMP	STRUCTURE IN WALNUT WOOD; CONNECTION BOX AND DETAILS IN F_41 (DARK NICKEL FINISH)	2 LED STRIP LIGHTS
-------------------	-----------	---	-----------------------

3321-GG-FC	WALL LAMP	STRUCTURE IN WALNUT WOOD; CONNECTION BOX AND DETAILS IN F_16 (LIGHT GOLD FINISH)	2 LED STRIP LIGHTS
-------------------	-----------	--	-----------------------

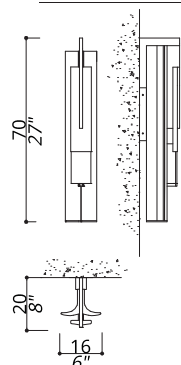

3322-DN-AC	WALL LAMP	STRUCTURE IN WALNUT WOOD; CONNECTION BOX AND DETAILS IN F_41 (DARK NICKEL FINISH)	2 LED STRIP LIGHTS
-------------------	-----------	---	-----------------------

3322-GG-FC	WALL LAMP	STRUCTURE IN WALNUT WOOD; CONNECTION BOX AND DETAILS IN F_16 (LIGHT GOLD FINISH)	2 LED STRIP LIGHTS
-------------------	-----------	--	-----------------------

ANIMA

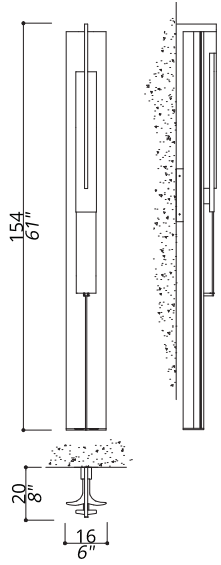

3323-DN-AC

MAXI
WALL LAMP

STRUCTURE IN WALNUT WOOD;
CONNECTION BOX AND DETAILS
IN F_41 (DARK NICKEL FINISH)

2 LED
STRIP LIGHTS

3323-GG-FC

MAXI
WALL LAMP

STRUCTURE IN WALNUT WOOD;
CONNECTION BOX AND DETAILS
IN F_16 (LIGHT GOLD FINISH)

2 LED
STRIP LIGHTS

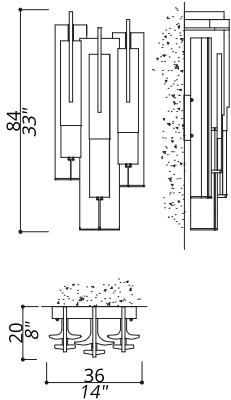

3325-DN-AC

WALL LAMP

STRUCTURE IN WALNUT WOOD;
CONNECTION BOX AND DETAILS
IN F_41 (DARK NICKEL FINISH)

6 LED
STRIP LIGHTS

3325-GG-FC

WALL LAMP

STRUCTURE IN WALNUT WOOD;
CONNECTION BOX AND DETAILS
IN F_16 (LIGHT GOLD FINISH)

6 LED
STRIP LIGHTS

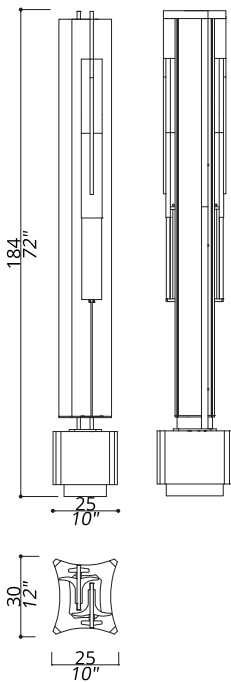

3341-DN-AC

FLOOR LAMP

STRUCTURE IN WALNUT WOOD;
DETAILS IN F_41 (DARK NICKEL FINISH).
TRAVERTINO MARBLE BASE

4 LED
STRIP LIGHTS

3341-GG-FC

FLOOR LAMP

STRUCTURE IN WALNUT WOOD;
DETAILS IN F_16 (LIGHT GOLD FINISH).
TRAVERTINO MARBLE BASE

4 LED
STRIP LIGHTS

NEST

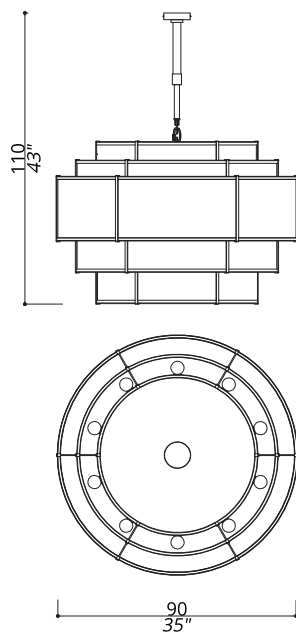

4111-GG-MN	CHANDELIER	5 SHADES COMPOSITION STRUCTURE AND CONNECTION BOX IN F_16 (LIGHT GOLD FINISH), SHADES IN NICKEL METAL MESH AND FABRIC	20 LIGHTS TYPE E14
4111-GG-MR	CHANDELIER	STRUCTURE AND CONNECTION BOX IN F_16 (LIGHT GOLD FINISH), SHADES IN COPPER METAL MESH AND FABRIC	20 LIGHTS TYPE E14
4111-GG-22	CHANDELIER	STRUCTURE AND CONNECTION BOX IN F_16 (LIGHT GOLD FINISH), SHADES IN FABRICS	20 LIGHTS TYPE E14

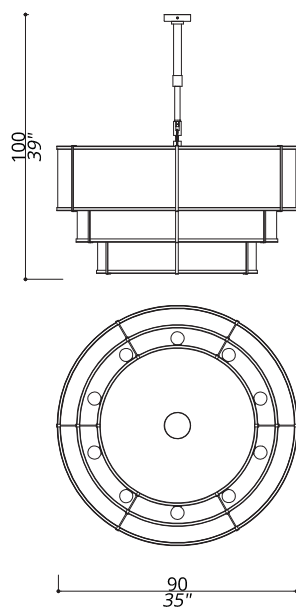

4112-GG-MN	CHANDELIER	3 SHADES COMPOSITION STRUCTURE AND CONNECTION BOX IN F_16 (LIGHT GOLD FINISH), SHADES IN NICKEL METAL MESH AND FABRIC	10 LIGHTS TYPE E14
4112-GG-MR	CHANDELIER	STRUCTURE AND CONNECTION BOX IN F_16 (LIGHT GOLD FINISH), SHADES IN COPPER METAL MESH AND FABRIC	10 LIGHTS TYPE E14
4112-GG-22	CHANDELIER	STRUCTURE AND CONNECTION BOX IN F_16 (LIGHT GOLD FINISH), SHADES IN FABRICS	10 LIGHTS TYPE E14

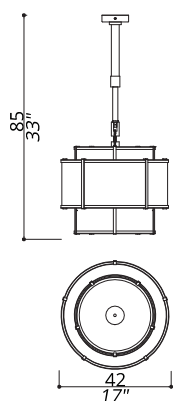

4113-GG-MN	SUSPENSION	3 SHADES COMPOSITION STRUCTURE AND CONNECTION BOX IN F_16 (LIGHT GOLD FINISH), SHADES IN NICKEL METAL MESH AND FABRIC	4 LIGHTS TYPE E14
4113-GG-MR	SUSPENSION	STRUCTURE AND CONNECTION BOX IN F_16 (LIGHT GOLD FINISH), SHADES IN COPPER METAL MESH AND FABRIC	4 LIGHTS TYPE E14
4113-GG-22	SUSPENSION	STRUCTURE AND CONNECTION BOX IN F_16 (LIGHT GOLD FINISH), SHADES IN FABRICS	4 LIGHTS TYPE E14

NEST

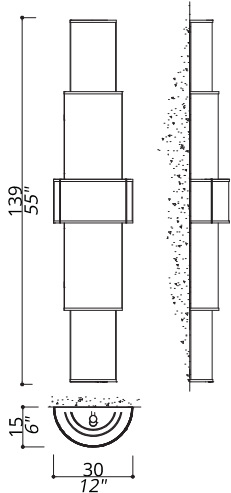

4121-GG-MN	WALL LAMP	5 SHADES COMPOSITION STRUCTURE AND CONNECTION BOX IN F_16 (LIGHT GOLD FINISH). SHADES IN NICKEL METAL MESH AND FABRIC	10 LIGHTS TYPE E14
-------------------	-----------	--	-----------------------

4121-GG-MR	WALL LAMP	STRUCTURE AND CONNECTION BOX IN F_16 (LIGHT GOLD FINISH). SHADES IN COPPER METAL MESH AND FABRIC	10 LIGHTS TYPE E14
-------------------	-----------	--	-----------------------

4121-GG-22	WALL LAMP	STRUCTURE AND CONNECTION BOX IN F_16 (LIGHT GOLD FINISH). SHADES IN FABRICS	10 LIGHTS TYPE E14
-------------------	-----------	---	-----------------------

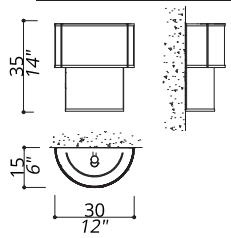

4122-GG-MN	WALL LAMP	STRUCTURE AND CONNECTION BOX IN F_16 (LIGHT GOLD FINISH). SHADES IN NICKEL METAL MESH AND FABRIC	2 LIGHTS TYPE E14
-------------------	-----------	--	----------------------

4122-GG-MR	WALL LAMP	STRUCTURE AND CONNECTION BOX IN F_16 (LIGHT GOLD FINISH). SHADES IN COPPER METAL MESH AND FABRIC	2 LIGHTS TYPE E14
-------------------	-----------	--	----------------------

4122-GG-22	WALL LAMP	STRUCTURE AND CONNECTION BOX IN F_16 (LIGHT GOLD FINISH). SHADES IN FABRICS	2 LIGHTS TYPE E14
-------------------	-----------	---	----------------------

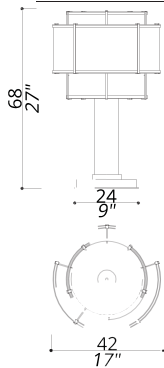

4131-GG-MN	TABLE LAMP	STRUCTURE IN F_16 (LIGHT GOLD FINISH). SHADES IN NICKEL METAL MESH AND FABRIC. CALACATTA MARBLE BASE	4 LIGHTS TYPE E14
-------------------	------------	--	----------------------

4131-GG-MR	TABLE LAMP	STRUCTURE IN F_16 (LIGHT GOLD FINISH). SHADES IN COPPER METAL MESH AND FABRIC. CALACATTA MARBLE BASE	4 LIGHTS TYPE E14
-------------------	------------	--	----------------------

4131-GG-22	TABLE LAMP	STRUCTURE IN F_16 (LIGHT GOLD FINISH). SHADES IN FABRICS. CALACATTA MARBLE BASE	4 LIGHTS TYPE E14
-------------------	------------	---	----------------------

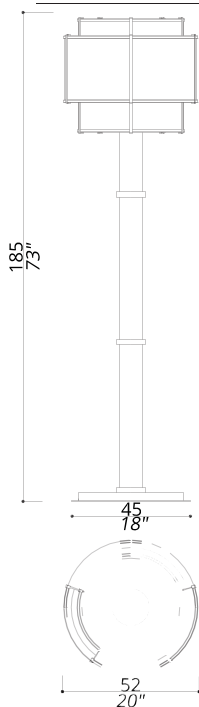

4141-GG-MN	FLOOR LAMP	STRUCTURE IN F_16 (LIGHT GOLD FINISH). SHADES IN NICKEL METAL MESH AND FABRIC. CALACATTA MARBLE BASE	6 LIGHTS TYPE E14
-------------------	------------	--	----------------------

4141-GG-MR	FLOOR LAMP	STRUCTURE IN F_16 (LIGHT GOLD FINISH). SHADES IN COPPER METAL MESH AND FABRIC. CALACATTA MARBLE BASE	6 LIGHTS TYPE E14
-------------------	------------	--	----------------------

4141-GG-22	FLOOR LAMP	STRUCTURE IN F_16 (LIGHT GOLD FINISH). SHADES IN FABRICS. CALACATTA MARBLE BASE	6 LIGHTS TYPE E14
-------------------	------------	---	----------------------

KEY

CODE STRUCTURE

The codes indicated in the present catalogue are formed by three parts:

The first for the product, the second for the composition of different metallic finishes and the third for the fabric of the shades. Details about composition of metallic finishes and fabrics are listed in the corresponding lists (Metallic Finishes, Shade Fabrics).

I codici indicati nel presente catalogo sono formati da tre parti:

Il primo per l'articolo, il secondo per la composizione di differenti finiture metalliche, il terzo per tessuti per paralumi.

I dettagli sulle finiture che formano le differenti composizioni finiture e sui tessuti sono riportati nelle successive tabelle (Metallic Finishes, Shade Fabrics).

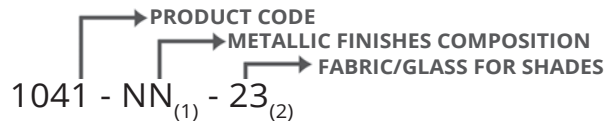

(1) SELECTION OF FINISH COMBINATIONS

BB | COMBINATION OF BRASS FINISHES

Includes at least two of the following: **F_10** natural brass, **F_12** brushed&burnished brass, **F_13** burnished copper finishes.

NN | COMBINATION OF NICKEL FINISHES

Includes at least two of the following: **F_31** polished nickel, **F_33** satin nickel, **F_35** antiqued nickel, **F_41** polished black nickel and **F_45** brushed black nickel finishes.

GG | COMBINATION OF GOLD FINISHES

F_14 polished gold, **F_15** satin gold, **F_16** light gold finishes.

GJ GK GC | COMBINATION OF GOLD FINISHES AND COLORED COATING

Includes the following: **F_14** polished gold, **F_15** satin gold, **F_16** light gold finishes; **L_55** beige, **L_56** black matte, **L_57** white coatings.

NN | COMBINATION OF NICKEL FINISHES

F_31 polished nickel, **F_33** satin nickel, **F_35** antiqued nickel finishes.

NJ NK NC | COMBINATION OF NICKEL FINISHES AND COLORED COATING

Includes the following: **F_31** polished nickel, **F_33** satin nickel, **F_35** antiqued nickel finishes; **L_55** beige, **L_56** black matte, **L_57** white coatings.

DN | COMBINATION OF DARK NICKEL FINISHES

F_41 polished black nickel, **F_45** brushed black nickel finishes.

RR | COMBINATION OF COPPER FINISHES

F_21 polished copper, brushed copper finishes.

RJ RK RC | COMBINATION OF COPPER FINISH AND COLORED COATING

Includes the following: **F_21** polished copper finish; **L_55** beige, **L_56** black matte, **L_57** white coatings.

GW NW | COMBINATION OF GOLD FINISH OR NIKEL FINISH AND EBONY WOOD

F_15 satin gold finish or **F_35** antiqued nickel finish and ebony wood.

For the complete finish list, please see **Finishes**.

(2) SELECTION OF SHADE OPTIONS

For the complete fabric list, please see **Fabrics**.

X | Fume' glass sticks.

S | Satin glass shades.

TC AC FC BC | Transparent, Amber, Fumè or Blue Crystal shades.

MR | metallic copper net shades.

Requests of finishes, fabrics, crystals, marbles which are different from what specified in the price-list and from what shown in the pictures of the catalogue might result into price changes.

FABRICS



TS_01
Ivory crepon
Crepon avorio



TS_02
Beige crepon
Crepon beige

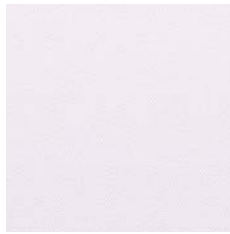

TS_04
White pongè
Pongè bianco



TS_05
Ivory pongè
Pongè avorio



TS_08
White parchment
Pergamena bianca

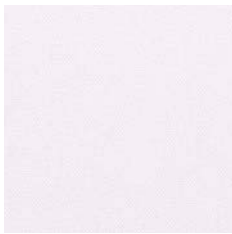

TS_06
White chinette
Chinette bianco

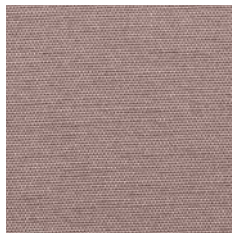

TS_07
Pink chinette
Chinette rosa

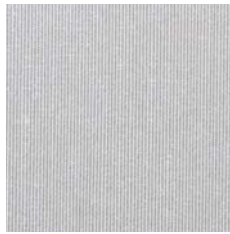

TS_10
Light gray shantung
Shantung grigio chiaro

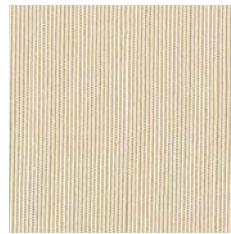

TS_11
Ivory shantung
Shantung avorio



TS_09
Ivory parchment
Pergamena avorio



TS_22
Ivory trevira wave
Rete trevira avorio



TS_23
Silver trevira wave
Rete trevira argento



TS_24
Gold trevira wave
Rete trevira oro



TS_25
Black trevira wave
Rete trevira nera

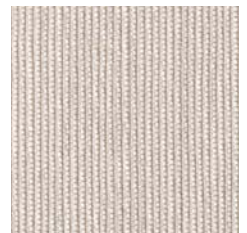

TS_27
Beige linen
Lino beige

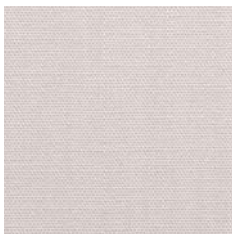

TS_35
Light gray linen
Lino grigio chiaro



TS_26
Chestnut brown satin
Raso marrone castagna

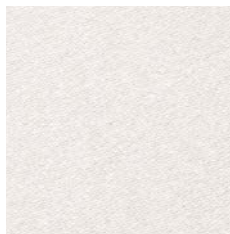

TS_28
Ivory satin
Raso avorio



TS_29
Gray satin
Raso grigio



TS_30
Beige satin
Raso beige



TS_41
Sage green satin
Raso verde salvia

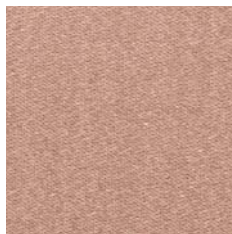

TS_32
Hazel satin
Raso nocciola



TS_33
Pink satin
Raso rosa



TS_31
Cream satin
Raso crema



TS_42
Blue satin
Raso blu

FINISHES



F_16
Polished light gold finish
Finitura oro chiaro lucido



F_14
Polished gold finish
Finitura oro lucido



F_21
Polished copper finish
Finitura rame lucido



F_15
Satin gold finish
Finitura oro satinato



F_10
Natural Brass
Ottone Naturale



F_12
Brushed&burnished brass
Ottone brunito&spazzolato



F_13
Burnished copper finish
Finitura rame brunito



F_41
Polished black nickel finish
Finitura nickel nero lucido



F_45
Brushed black nickel finish
Finitura nickel nero spazzolato



F_31
Polished nickel finish
Finitura nickel lucido



F_33
Satin nickel finish
Finitura nickel satinato

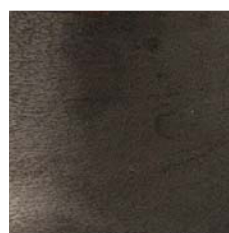

F_35
Antiqued nickel finish
Finitura nickel anticato



F_57
White finish
Verniciatura bianca

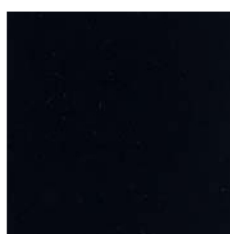

F_56
Black matte finish
Verniciatura nero matte



F_55
Beige finish
Verniciatura beige

MARBLES

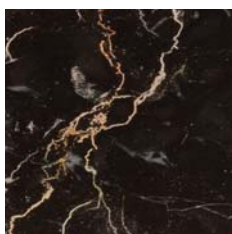

PORTORO



CALACATTA

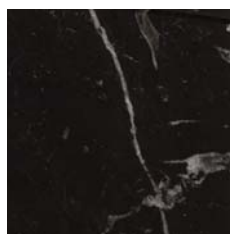

MARQUINIA



CARRARA



TRAVERTINO



BARDIGLIO

LEATHER

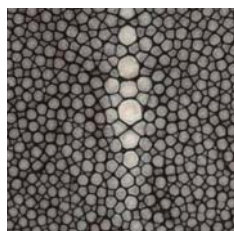

GALUCHAT
Dark Gray
Collection Flute

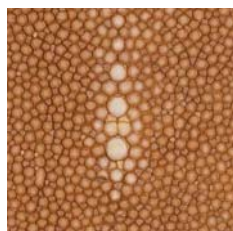

GALUCHAT
Ochre
Collection Flute



GALUCHAT
Light Green
Collection Flute



LEATHER
Gray
Collection Eteera



LEATHER
Black
Collection New Flow

CRYSTALS



CRYSTALS
Transparent
Collections Eteera, Anima

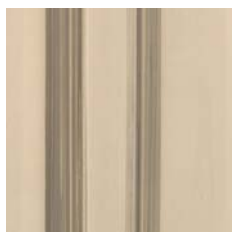

CRYSTALS
Amber
Collections Eteera, Anima



CRYSTALS
Fumè
Collections Eteera, Anima



CRYSTALS
Blue
Collections Eteera, Anima

CREDITS

DESIGN | EMANUELA BENEDETTI
Collections **Eterea, Soave, Anima**

DESIGN | ANTONIO MINUTELLA
Collection **Nest**

DESIGN | MAURIZIO ARENA
Collections **Flute, Crea, Bloom, Flaire, Marble Flaire, Top, Top Glass, Glam, Trapeze, Grace, Saba, Flow, New Flow, Shade, New Shade, Shine**

PHOTOGRAPHY | FRANCESCO BEDINI

Except for following:

PHOTOGRAPHY | PATRICK JOHN STEINER
EDITING & POST PRODUCTION | SAMUELE MANCINI
Intro to Collections Eterea, Soave, Anima at pages 10-26-32

PHOTOGRAPHY | ANTONIO SABA, *IHDG SHOWROOM DUBAI*
Collection Anima interiors view and intro to Collection Saba at pages 34&35-114

DESIGN | ART HALL, *PRIVATE PROJECT MOSCOW*
Intro to Collection Flow at page 48

DESIGN | PROPHILO, *EXPO MILAN*
Intro to Collection Crea at page 142

PRINTING | TAP GRAFICHE
San Gimignano, 2018



OFFICINA LUCE

is a trademark of issarch srl.

All concepts, designs, arrangements, drawings and specifications are owned by and are the property of issarch srl. Issarch srl reserves the right to change, at any time and without prior warning, the technical specifications of any product illustrated in this catalogue.

ISSARCH SRL
VIA VANNETTI DONNINI, 71
59100 PRATO (PO)
ITALY

WWW.OFFICINA-LUCE.COM

T: +39 0574 054529 | E: INFO@OFFICINA-LUCE.IT